

# KENYA JUNIOR SCHOOL EDUCATION ASSESSMENT

## GRADE 9 - YEAR 2026

### MATHEMATICS



001

Name \_\_\_\_\_

Assessment No. \_\_\_\_\_

School \_\_\_\_\_

Date \_\_\_\_\_

**Instructions:** This paper consists of two sections A and B

**TIME: 2HRS**

**SECTION A: (20 MARKS)**

1. The national census recorded a total population of **47582619** people in a country. What is this number rounded off to the nearest tens of millions?  
 A. 40000000      B. 48000000  
 C. 47600000      D. 50000000
2. During a Science experiment, the temperature of water was recorded as  $58^{\circ}\text{C}$ . What was the temperature of the water in Kelvin?  
 A. 215K              B. 273K  
 C. 331K              D. 48K
3. Work out the problem below  

$$\sqrt{2\frac{14}{25}} - \left(\frac{2}{5}\right)^2$$
 A.  $\frac{4}{5}$                   B.  $1\frac{11}{25}$   
 C.  $2\frac{2}{5}$                   D.  $1\frac{3}{5}$
4. A shop offers a 10% discount on a phone priced between sh. 15000 and sh. 25000. How much does one pay for a phone marked at sh. 18000?  
 A. sh. 18000      B. sh. 16200  
 C. sh. 1800        D. sh. 19800
5. A container in the shape of a cube has a volume of  $13.144 \text{ cm}^3$ , use Mathematics tables to determine the side of the cube  
 A. sh. 4.72cm      B. sh. 472cm  
 C. sh. 2.36cm      D. sh. 236 cm
6. The measure of each interior angle of a regular polygon is  $150^{\circ}$ . How many sides does the polygon have?  
 A. 12                  B. 8  
 C. 6                    D. 10

7. What is the difference in the total value of digit 5 and digit 2 in the number 457823?  
 A. 50020              B. 49980  
 C. 50000              D. 20
8. The surface area of an open cube is  $405\text{cm}^2$ . What is its volume?  
 A.  $216\text{cm}^3$           B.  $243\text{cm}^3$   
 C.  $729\text{cm}^3$           D.  $135\text{cm}^3$
9. In the figure below lines **AB**, and **CD** are parallel. Line **XY** is a transversal line.

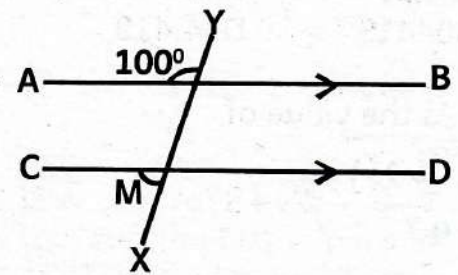

What is the measure of the angle marked **M**?  
 A.  $180^{\circ}$                   B.  $26^{\circ}$   
 C.  $100^{\circ}$                 D.  $80^{\circ}$

10. Solve the following linear equation.  
 $2x + 4y = 80$   
 $5x + 2y = 20$   
 A.  $x = 20, y = 0$       B.  $x = 10, y = 15$   
 C.  $x = 0, y = 20$       D.  $x = 15, y = 10$
11. A bag contains 3 red pens and 5 blue pens. Find the probability of picking a blue pen from the bag.  
 A.  $\frac{1}{5}$                       B.  $\frac{3}{8}$   
 C.  $\frac{1}{3}$                       D.  $\frac{5}{8}$
12. Yohana deposited ksh. 50000 in a saving account which paid a compound interest of 10% p.a. Find the total amount of the money at the end of 3 years?  
 A. Ksh. 65000          B. ksh 16550  
 C. ksh 66550          D. ksh 15000

13. Express 940.87 to four significant figures

- A. 940.8                      B. 940.9  
C. 940.870                  D. 941.0

14. Evaluate:

$$(+18) + (-3) + (-8)$$

- A. 7                              B. -7  
C. -13                          D. 13

15. Work out the following problem.

$$4.05^2$$

- A. 16.425                      B. 1.64025  
C. 16.4025                  D. 164.025

16. Some dice are stacked in a box such that there are 6 dice along the length, width and height. Find the number of dice in the box.

- A. 64                              B. 216  
C. 36                              D. 96

17. Use a table of cubes to find the cube of 0.1641.

- A. 0.04419                      B. 0.4419  
C. 0.004419                      D. 4.419

18. What is the value of

$$\frac{12(8^2 - 2^2)}{9} - 48 \div 8?$$

- A. 86                              B. 79  
C. 80                              D. 74

19. 12 men can do a piece of work for twenty days. After working for 4 days, 4 more men are employed. How many less days will they work take?

- A. 4                                B. 12  
C. 16                              D. 8

20. Calculate the area of the shaded part in the figure below.

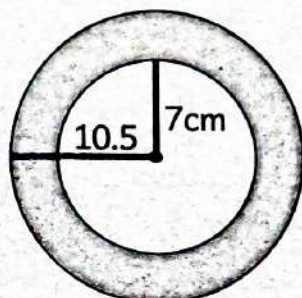

- A. 346.5cm<sup>2</sup>                      B. 192.5cm<sup>2</sup>  
C. 616.0cm<sup>2</sup>                      D. 154.0cm<sup>2</sup>

## SECTION B: (80 MARKS)

Answer all the questions in the spaces provided

21. Solve the linear equation below for the values of X and Y using elimination method. (5mks)

$$3x + 2y = 19$$

$$2x - y = 1$$

22. Grade 9 learners were learning about cube roots of numbers. A Maths teacher had written a problem on the board and requested learners to evaluate. (5mks)

$$\sqrt[3]{8a^9b^6}$$

23. The diagram below shows a plot of land drawn to a scale of 1:10000.

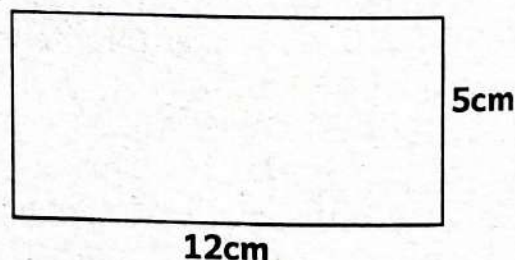

What is the actual area of the land in hectares? (5mks)

24. What is the value of; (6mks)

$$\frac{1}{2} + \frac{9}{10} \div \frac{18}{5} - \frac{1}{5} \text{ of } \frac{1}{4}?$$

25. Given that  $a = b+1$ ,  $b=4$  and  $c = b-1$ , find the value of; (6mks)

$$\frac{\sqrt{a^2} \times \sqrt{3b-c}}{c}$$

26. A family spends  $\frac{1}{4}$  of its monthly income on food,  $\frac{1}{3}$  on rent and saves the rest.

(a). What fraction of the income does the family save? (4mks)

(b). If their total monthly income is sh. 60000, how much more money do they save than they spend on rent? (4mks)

27. A business made a profit of sh. 1200000. Twenty percentage of the profit was invested back in the business while the rest was to be shared among three partners, John, Tom and Makori in the ratio of their investment 2:3:5 respectively. How much profit does each partner receive? (6mks)

28. A student calculates a value as 0.45 on a calculator. Express this value as a fraction in its simplest form. (4mks)

29. The diagram below is a trapezium  $MNPQ$ . Line  $MQ$  is parallel to line  $NP$ . The length of line  $MQ = 8\text{cm}$  and that of line  $NR = 7\text{cm}$ . The perpendicular line  $MR = 12\text{cm}$ .

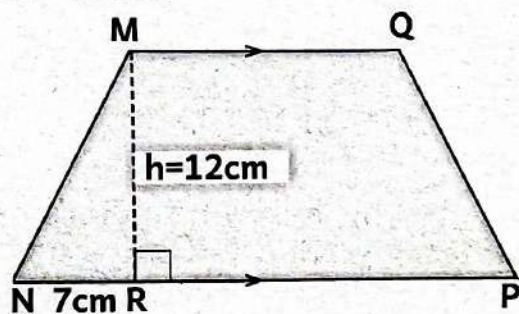

If the area of a trapezium is  $198\text{cm}^2$ , What is the length of  $RP$ ? (6mks)

30. The figure below shows a triangular prism

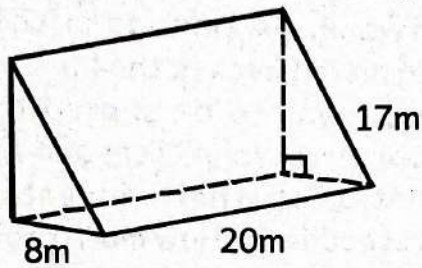

What is the total surface area? (6mks)

31. What is the sum of the total value of digits in hundreds and ten thousand in the number 3768532? (4mks)

32. Grade 9 learners were given a Cartesian to plot some coordinates.

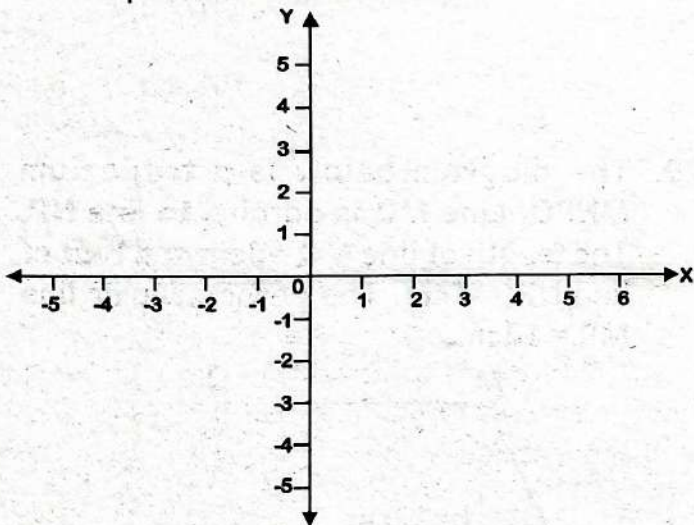

Locate the following points on the Cartesian plane.

- (i) X (1, 3) (2mks)
- (ii) M (-2, 3) (2mks)
- (iii) Q (-3, 0) (2mks)

33. Express the following numbers in standard form (4mks)

(a). 0.00000985

(b). 150678

(c). 27432000

(d). 36.857

34. Simplify the following;

$$\frac{1}{4}(24x+28y) + \frac{1}{3}(9x-6y) \quad (4mks)$$

35. Find the capacity of the container below in litres (Take  $\pi = \frac{22}{7}$ ) (5mks)

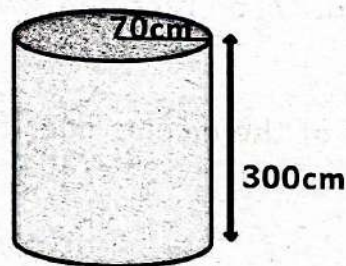

36. The radius of a wheel is 56cm.

Work out;

- (a). Its circumference (2mks)
- (b). The distance moved by the same wheel if it makes 1000 revolutions on a flat surface in metres. (4mks)

# KENYA JUNIOR SCHOOL EDUCATION ASSESSMENT

## GRADE 9 - YEAR 2026

### ENGLISH PAPER 1



001

(READING COMPREHENSION, ORAL SKILLS AND GRAMMAR)

Name \_\_\_\_\_ Assessment No. \_\_\_\_\_

School \_\_\_\_\_ Date \_\_\_\_\_

Instructions: Answer all questions.

TIME: 1HR. 40MINUTES

**Read the passage below and then answer questions 1 to 6.**

Do you watch cartoons on TV? If you do, you may know the famous cartoon show *Tom and Jerry*. It is one of the most famous cartoon shows in the world. Each show is about seven minutes long. This show has won many film awards.

Tom and Jerry are the two main characters in the show. Tom is a cat. His full name is "Tom Cat: which refers to male cats. He is always after Jerry the mouse. Many of the traps set for Jerry **backfire** and hurt Tom himself rather than Jerry.

Tom does not want to eat Jerry. He bothers Jerry and wants to hurt him. He keeps chasing him. However, Tom cannot catch him easily. Jerry is clever, smart and lucky.

Tom and Jerry are not enemies to each other all the time. There are times they show friendship. Tom and Jerry show is very funny. It makes you laugh a lot. In addition, this show gives you a message, "Love your enemies." When Tom and Jerry fight, they are always in problem. When they are friends, everything goes easy. When Tom and Jerry have a common goal or same task to do, they come and work together.

- |   |   |
|---|---|
| <p>1. What is <b>not</b> true, according to the passage, about Tom and Jerry?<br/>A. Tom always wants to eat Jerry<br/>B. Tom and Jerry are the main characters in the show<br/>C. Tom and Jerry is among the famous cartoon shows.<br/>D. Tom is a cat while Jerry is a mouse</p> <p>2. Jerry outsmarts Tom in the following ways <b>except</b><br/>A. smartness                      B. luck<br/>C. cleverness                      D. speed.</p> <p>3. Why do you think Tom and Jerry show is very popular?<br/>A. It is known to last seven minutes<br/>B. It is funny and makes someone laugh<br/>C. The characters in the show are animal<br/>D. It has won many film awards.</p> | <p>4. The word "<b>backfire</b>" as used in the passage means<br/>A. to succeed<br/>B. to burst in flames<br/>C. to go wrong<br/>D. to repeat.</p> <p>5. When Tom and Jerry are friends<br/>A. everything goes smoothly<br/>B. Tom sets more traps for Jerry<br/>C. Tom wants to eat Jerry<br/>D. a problem arises and they fight.</p> <p>6. Which one of the following is the main message in the cartoon show, Tom and Jerry?<br/>A. It is good to be famous<br/>B. Laughter is the best medicine<br/>C. Always work together<br/>D. Love your enemies.</p> |
|---|---|

**Read the passage below and then answer questions 7 to 11.**

Exercise is one of the best things we can do to keep our bodies and minds healthy. When we exercise, our muscles and bones get stronger. Furthermore, it makes us feel energetic and helps us stay active all day. Activities such as jogging, jumping or cycling make our hearts and lungs stronger as well as improving blood circulation.

Exercise is not only good for our body but also for our mind. It help us feel happy and reduce stress. For instance, after playing a game of football, we often feel relaxed and joyful. It also improves our memory and helps us do better in school.

Most importantly, exercise teaches us discipline by keeping time and sticking to a programme. Last but not the least, regular exercise strengthens our immune system, protecting us from illness.

- |  |   |
|--|---|
| <p>7. From paragraph one, we can say that exercise</p> <p>A. makes our muscles weak<br/>B. makes our bones weak<br/>C. keeps our minds healthy<br/>D. makes us idle all day.</p> <p>8. A strong heart and lungs <b>cannot</b> be as a result of</p> <p>A. jumping                      B. jogging<br/>C. cycling                        D. sleeping</p> <p>9. The word "<b>joyful</b>" as used in the passage, cannot be replaced by</p> <p>A. happy                         B. cheerful<br/>C. amazed                       D. jubilant</p> | <p>10. How does doing exercise enhance discipline?</p> <p>A. By keeping time and sticking to a programme<br/>B. By improving blood circulation<br/>C. By making us happy and reducing stress<br/>D. By strengthening our immune system</p> <p>11. Which one of the following would be the <b>most</b> suitable title for this passage?</p> <p>A. Working hard in school<br/>B. Value of exercise<br/>C. Strength and immunity<br/>D. Being disciplined.</p> |
|--|---|

**Read the passage below and then answer questions 12 to 16.**

Learning is an **essential** part of life. It is how we grow and improve ourselves every day. By learning, we gain knowledge about the world around us. For example, we learn how plants grow, why the sky is blue, or how to solve Maths problems. Learning also teaches us important skills. We learn how to read, write and even play games. These skills help us achieve our goals and dreams.

Learning does not just happen in schools. We learn at home, from our parents and friends, and even by watching nature. When we make mistakes, we learn how to do better next time. Learning also makes us kind and helpful. It teaches us teamwork and respect for others. In conclusion, learning prepares us for challenges in life. It gives us the confidence to solve problems and try new things.

- |   |   |
|---|---|
| <p>12. According to the passage, the following skills are acquired through learning <b>except</b></p> <p>A. writing<br/>B. playing games<br/>C. reading<br/>D. solving Maths problems</p> <p>13. Which one of the following does <b>not</b> include the world around us?</p> <p>A. Goals and dreams<br/>B. The sky<br/>C. Mathematical problems<br/>D. Plants</p> | <p>14. The word '<b>essential</b>' as used in the passage means the same as</p> <p>A. difficult                      B. necessary<br/>C. relevant                       D. optional</p> <p>15. According to the passage, which one of the following is <b>not</b> a life skill gained from learning?</p> <p>A. Confidence                 B. Respect<br/>C. Brilliance                    D. Teamwork</p> <p>16. Choose the <b>most</b> suitable title for this passage.</p> <p>A. Knowledge                 B. Challenges<br/>C. Achievement               D. Learning</p> |
|---|---|

**Read the passage below and then answer questions 17 to 20.**

Omari, Kaka, Tinga and Anene went to a restaurant. Kaka and Anene took tea and doughnut. Omari and Tinga took tea and sausage. Kaka took soup and sausage.

17. Who ate the most?

- A. Kaka                      B. Omari  
C. Anene                     D. Tinga

18. Which foodstuff was not popular?

- A. Sausage  
B. Soup  
C. Tea  
D. Doughnut

19. Which foodstuff was taken by most people?

- A. Doughnut                B. Sausage  
C. Tea                        D. Soup

20. Sausage was taken by all except

- A. Tinga                      B. Kaka  
C. Omari                     D. Anene

**Read the following telephone conversation. It contains blank spaces numbered 21 to 25.**

**For each blank space, select the best alternative from the choices given.**

**Courier:** Welcome to our on-line services. \_\_\_\_\_ 21 \_\_\_\_\_?

**Customer:** Hello, I would like chicken and chips.

**Cuourier:** \_\_\_\_\_ 22 \_\_\_\_\_! Would you like anything else?

**Customer:** \_\_\_\_\_ 23 \_\_\_\_\_, I would like four sausages.

**Courier:** Okay. Your delivery will be done as soon as possible.

**Customer:** \_\_\_\_\_ 24 \_\_\_\_\_ for your response.

**Courier:** \_\_\_\_\_ 25 \_\_\_\_\_.

21. A. What would you like to order  
B. Have you eaten today  
C. Why are you calling  
D. What's your favourite food.

22. A. Yummy                      B. Congratulations                      C. Amazing                      D. Great choice  
23. A. No                              B. Yes                                      C. Pardon                              D. Perhaps.  
24. A. Excuse me                      B. Alright                                      C. Thank you                              D. I'm sorry  
25. A. You're welcome                      B. See you                                      C. Good day                              D. Goodbye.

**Read the passage below and then choose the best alternative to fill in the gaps 26 to 35.**

We \_\_\_\_\_ 26 \_\_\_\_\_ practise talking everyday in English \_\_\_\_\_ 27 \_\_\_\_\_ to achieve fluency. \_\_\_\_\_ 28 \_\_\_\_\_ people are afraid to speak because they are shy \_\_\_\_\_ 29 \_\_\_\_\_ other people will think if they \_\_\_\_\_ 30 \_\_\_\_\_ mistakes. \_\_\_\_\_ 31 \_\_\_\_\_, mistakes are very common so there is no need to worry. In the beginning \_\_\_\_\_ 32 \_\_\_\_\_ has a challenge. Moreover, \_\_\_\_\_ 33 \_\_\_\_\_ have friends \_\_\_\_\_ 34 \_\_\_\_\_ one willing to improve their English and practise with them \_\_\_\_\_ 35 \_\_\_\_\_ possible.

- |                    |                  |               |               |
|--------------------|------------------|---------------|---------------|
| 26. A. would       | B. shall         | C. will       | D. should     |
| 27. A. due         | B. incase        | C. in order   | D. because    |
| 28. A. Every       | B. Many          | C. All        | D. More       |
| 29. A. what        | B. how           | C. why        | D. when       |
| 30. A. do          | B. create        | C. make       | D. put        |
| 31. A. Furthermore | B. Instead       | C. Although   | D. However    |
| 32. A. everybody   | B. everything    | C. nobody     | D. no one     |
| 33. A. hardly      | B. always        | C. never      | D. rarely     |
| 34. A. whom        | B. which         | C. who        | D. whose      |
| 35. A. as well as  | B. as quickly as | C. as soon as | D. as much as |

**For questions 36 to 50, select the alternative that best completes the sentence.**

36. She bought several \_\_\_\_\_ of biscuits.  
A. packets                      B. trays  
C. crates                         D. dozens
37. Do you know \_\_\_\_\_ who can operate this machine?  
A. something                    B. anybody  
C. no one                         D. nobody
38. Martin has a new sweater, \_\_\_\_\_?  
A. don't he                        B. does he  
C. do he                            D. doesn't he
39. If we keep time, we \_\_\_\_\_ catch the first train.  
A. will                                B. can  
C. would                            D. could
40. My drawing skill is getting better and  
A. best                                B. more better  
C. better                             D. most better.
41. Halima missed the school bus \_\_\_\_\_ she was the late.  
A. or                                    B. because  
C. but                                 D. and
42. He was \_\_\_\_\_ injured so he went on playing for the team.  
A. badly                              B. severely  
C. extremely                        D. slightly
43. The children enjoyed \_\_\_\_\_ playing in the sand.  
A. themselves                    B. herself  
C. itself                                D. himself
44. Mr. Eagle and \_\_\_\_\_ arranged the laboratory.  
A. them                                B. their  
C. they                                 D. theirs.
45. They were suddenly attacked by a \_\_\_\_\_ of bees.  
A. flock                                B. swarm  
C. herd                                 D. pack
46. I have known this lady \_\_\_\_\_ many years.  
A. by                                    B. since  
C. with                                 D. for
47. The team cannot win \_\_\_\_\_ all the players practise hard.  
A. since                                B. although  
C. unless                              D. incase.
48. We need \_\_\_\_\_ cement to mix with the sand.  
A. few                                 B. little  
C. a few                                D. a little
49. One of \_\_\_\_\_ tables has a broken leg.  
A. these                                B. this  
C. that                                 D. them.
50. The detectives are busy \_\_\_\_\_ the mysterious murder case.  
A. looking after  
B. looking into  
C. looking out for  
D. looking up to



**SECTION B: LITERARY ANALYSIS (35mks)**

**TASK 2: ORAL LITERATURE (10mks)**

**2. Read the story below and then answer the questions that follow.**

Once upon a time, a humble woodcutter rescued an eagle from a deadly trap. Sometime later, the woodcutter had climbed on a steep hill to cut trees for wood. There he got stuck, and could not come down. He sat on a rock, stranded, waiting for any help to come.

Suddenly, the eagle he had rescued came flying down towards him. It flew away with his hat! The woodcutter became angry and started to chase the eagle. After some time of tracking, he found his way to get down the hill.

“Oh, so this is why you took my hat. You wanted me to run behind you and find this way. Thank you so much, my friend,” the woodcutter said to the eagle.

**(a). Identify the opening formula in the story.**

**(1mk)**

(b). Suppose you are narrating this story to your classmates, give three ways you would make it more interesting. (3mks)

(c). Give the most suitable character trait to the following. (2mks)

(i) Woodcutter \_\_\_\_\_

(ii) Eagle \_\_\_\_\_

(d). Why did the eagle fly away with the woodcutter's hat? (2mks)

(e). What moral lesson do we learn from this story? (2mks)

### **Task 3: POETRY (5mks)**

3. **Read the poem below and then answer the following questions.**

From the counting the number of bruises and blood stain,  
To hiding the identity of the one, who induced the pain.  
At the fragile age of being nurture,  
They gifted traumas to the future.  
Taking care of the childhood needs became flattering,  
Because the idea of saying no was frightening.  
It was in the middle of the game,  
For which there was a lifetime of shame  
The consent was of no use,  
They called it playtime to abuse.

(a). How many lines are in this poem? (1mk)

(b). The words 'pain' and 'stain' are rhyming words. Identify two pairs of rhyming words in the poem. (2mks)

(i). \_\_\_\_\_

(ii). \_\_\_\_\_

(c). Give the poem you have just read a suitable title. (2mks)

### **TASK 4: PLAY (10mks)**

4. **Below is a section of a play. Read it and then answer the questions that follow.**

*(Early morning. In an old rusty trailer used as a health facility. The patients queue waiting to see the doctor; one at a time. Mariko walks past the queue right to the front. The man at the front of the queue pushes him aside and points to the back of the queue. Mariko walks towards the back of the queue. He stops besides an old man who is coughing while reading a newspaper. Each time he coughs, he covers his mouth with his left hand)*

**Mariko:** Old man, you have a bad cough. (*The old man ignores him, turns the paper to another angle and continues to read, still with broad smiles at intervals*) Old man, remember we have been under siege. Siege from a bad bad cold. If you are not careful enough you can easily infect those around you just like they can infect you. You know what I mean? (*Laughs.*)

(a). Where do the events of this scene of the play take place? (2mks)

\_\_\_\_\_

(b). What is the **main** problem in this scene of the play? (2mks)

\_\_\_\_\_

(c). Who are the **main** characters in this scene of the play? (2mks)

\_\_\_\_\_

(d). With examples, identify **two** character traits of the old man. (2mks)

(i). \_\_\_\_\_

(ii). \_\_\_\_\_

**TASK 5: NOVELLA (10mks)**

5. **Below is a section of a novella. Read it and then answer the questions that follow.**

Kiyingu, Willy, Omido and I are sitting up. We are up the rock pile, above the compost pit filled with old brown beer bottles, above the plastic cans with peeling labels, above the car tyres we ride in the evenings after school, above the wet peels of potatoes and bananas that have started decomposing and gathering flies. From here, we can see the passing cars clearly and all the houses on Block A and Block B.

(a). What is the setting of the story? (2mks)

\_\_\_\_\_

(b). Name the **main** characters in this story. (4mks)

\_\_\_\_\_

(c). Why do you think the characters chose to sit up the rock pile? (2mks)

\_\_\_\_\_

(d). With examples, show how the place had poor sanitation. (2mks)

\_\_\_\_\_



001

## GREDI YA TISA - MWAKA 2026

KISWAHILI LUGHA: KARATASI YA 1

Jina \_\_\_\_\_ Nambari ya ujasili \_\_\_\_\_

Shule \_\_\_\_\_ Tarehe \_\_\_\_\_

Maagizo: Jibu maswali yote kwenye karatasi ya majibu uliyopewa

MUDA: SAA 1 DAK 40

**Soma taarifa ifuatayo kisha ujibu maswali 1 hadi 10.**

Siku moja mwanamke mmoja alikuwa akisafiri katika gari la abiria wakati wa usiku. Kumbe hakuwa na pesa za kutosha za nauli. Basi yule anayetoza pesa alipofika kwa mwanake huyo, alimwomba atoe nauli yake. Yule mwanamke akatoa pesa alizokuwa nazo, lakini yule utingo akasema kuwa hazikutosha. Mama yule alimwelezea bwana huyo hakuwa na zaidi, akamwomba amsamehe. Bwana huyo alikataa kabisa akasema kwamba itambidi huyo mama atoke katika gari. Wasafiri wengine waliona uchungu sana hata mmoja wao akajitolea kumtolea yule bibi nauli, lakini utingo akasema hatakubali pesa za mtu mwingine yeyote, kwani yule mama alikuwa anazo pesa, ila alitaka kufanya mzaha tu. Mama alizidi kulia hata akatokwa na machozi naye yule mtu aliyejitolea, alisema hakuwa akifanya **mzaha**. Mama alitoka huku analia.

Alipoteremka tu akanaswa na kushambuliwa na simba. Kwa bahati, palitokea gari la polisi walifukuza lile gari la abiria mpaka wakalishika. Walipoulizwa juu ya kisa hicho yule utingo alitaka kukana, lakini abiria wote walisema kwamba huyo mwanamke alikuwa katika basi hilo. Hapo basi yule utingo akashikwa na kupelekwa mahakamani. Akashitakiwa na kufungwa miaka kumi pamoja na viboko ishirini.

- |   |  |
|---|--|
| 1. Mwanamke alikuwa akisafiri wakati wa<br>A. mchana                      B. asubuhi<br>C. usiku                         D. jioni         | 7. Ni mnyama yupi aliyeshambulia yule mwanamke?<br>A. Mbwa                         B. Fisi<br>C. Chui                            D. Simba. |
| 2. Mwanamke hakuwa na nini ya kutosha?<br>A. chakula<br>B. Nauli<br>C. Nguo<br>D. Wasafiri.   | 8. Neno " <b>mzaha</b> " limepigwa mstari, linamaanisha<br>A. kumchezea mtu<br>B. kumtembelea mtu<br>C. kumwibia mtu<br>D. kuliwa.         |
| 3. Neno <b>nauli</b> linamaanisha<br>A. pesa                            B. chakula<br>C. nguo                            D. wasafiri      | 9. Utingo alishikwa na kupelekwa<br>A. mahakamani<br>B. jela<br>C. shuleni<br>D. kanisani.   |
| 4. Watu wanaosafiri kwa gari huitwa<br>A. abiria                         B. utingo<br>C. watalii                         D. makanga       | 10. Utingo alifungwa miaka mingapi?<br>A. Kumi                            B. Sita<br>C. Tano                             D. Nne.           |
| 5. Mtu anayeitisha pesa kwenye gari ni<br>A. makanga                      B. utingo<br>C. dereva                         D. polisi        |  |
| 6. Mwanamke alitolewa nje ya gari wapi?<br>A. Kituoni                         B. Nyumbani<br>C. Mwituni                         D. Njiani |  |

**Soma taarifa ifuatayo kisha ujibu maswali 11 hadi 20.**

Nchi yetu ya Kenya ina mbuga nyingi za wanyama. Mbuga hizi zinapatikana katika sehemu mbalimbali za Kenya. Mojawapo ya mbuga hizi ni Tsavo. Mbuga ya wanyama ya Tsavo imegawanywa na barabara kuu ya Nairobi kwenda Mombasa katika sehemu mbili. Kila sehemu iko chini ya uangalizi wa ofisa wa kulinda wanyama.

Watu wanaotaka kuwaona wanyama wa pori hutembelea mbuga za Tsavo. Katika mbuga ya wanyama ya Tsavo, kuna ndovu wengi.

Katika Tsavo ya Magharibi, kuna sehemu muhimu inayoitwa, “Mzima Springs” na vidimbwi vingi vya maji baridi ambamo viboko huishi. Pia kuna mahali maalum panapoitwa “Salt Lick” ambapo wanyama huenda na kuramba chumvi. Tsavo ya Mashariki ni kubwa kuliko ya Magharibi. Katika sehemu nyingine za mbuga hii watu hawaingii bila kuongozwa. Katika mbuga hii kuna hoteli za kisasa za kuhudumia watalii.

11. Mahali ambapo wanyamapori huishi na kutunzwa huitwa?  
A. Tsavo                      B. Zizi  
C. Mbuga                      D. Pori
12. Mbuga ya wanyama ya Tsavo imegawanywa mara mbili na  
A. ua                              B. barabara  
C. mto                             D. chemchemi
13. Hoteli ya kisasa iliyoko Tsavo huwahudumia  
A. wanyamapori      B. watalii  
C. walinzi                D. wasafiri.
14. Katika Tsavo, ni wanyama gani maarufu sana?  
A. Ndovu                      B. Kiboko  
C. Simba                      D. Chui
15. Viboko hupatikana wapi?  
A. Jangwani  
B. Tsavo Mashariki  
C. Tsavo Magharibi  
D. Barabarani
16. **Chagua jibu sahihi.**  
A. Tsavo Magharibi ni kubwa kuliko Tsavo Mashariki  
B. Vidimbwi vya maji hupatikana Tsavo Mashariki  
C. Wanyama wanaopatikana Tsavo ni ndovu na viboko tu!  
D. Kunao wanyama wengi Tsavo.
17. Tsavo iko chini ya uangalizi wa  
A. Afisa wa Afya  
B. Afisa wa elimu  
C. Afisa wa polisi  
D. Afisa wa kulinda wanyama.
18. Ili kupata madini muhimu mwilini, wanyama  
A. hunywa maji  
B. huramba chumvi  
C. hula sana  
D. hupewa dawa.
19. Mtu akitaka kufika Tsavo lazima abiria gari kuelekea au kutoka  
A. Nairobi  
B. Kisumu  
C. Mombasa  
D. Nyeri.
20. Kichwa kifaacho taarifa hii ni  
A. Wanyamapori  
B. Hoteli za kisasa  
C. Mbuga ya Tsavo  
D. Ndovu na kiboko

**Soma mazungumzo yafuatayo kisha ujibu maswali kutoka swali la 21 hadi 25.**

***(Ni alasiri, Zuri ameketi chini ya mti mkubwa shuleni akiwa ameinama uso wake ukionyesha huzuni. Ashton, rafiki yake wa karibu, anamkaribisha taratibu)***

**Ashtoni:** Zuri \_\_\_21\_\_\_? Mbona uko peke yako hapa chini ya mti?

**Zuri:** ***(Akiinamisha macho chini)*** Sina raha, rafiki yangu. Nimeshindwa mtihani wa hisabati. Walimu na wazazi wangu walitarajia nifanye vizuri.

**Ashton:** Pole sana, rafiki yangu. Lakini kushindwa si mwisho wa kila kitu.

**Zuri:** Najihisi kama nimewaangusha watu wanaonitegemea. Natamani ningekuwa bora zaidi.

**Ashton:** Kumbuka kuwa kila mmoja wetu hukumbana na changamoto maishani. La muhimu ni kujifunza kutokana na makosa na kujaribu tena.

**Zuri:** Wewe hujawahi kushindwa?

**Ashton:** Nimewahi, mara nyingi tu. Lakini nilijifunza kujikubali na kuendelea kujaribu. Hisia mbaya huja na kuondoka. Muhimu ni jinsi tunavyokabiliana nazo.

**Zuri:** Nashukuru kwa kunifariji. Nitajitahidi zaidi wakati ujao.

**Ashton:** \_\_\_25\_\_\_, rafiki yangu. Na kumbuka, uko na uwezo mkubwa kuliko unavyofikiri.

**21.** Chagua jibu sahihi kukamilisha nafasi ya 21 iliyoachwa kwenye kifungu.

- A. Ukoje                      B. Hujambo  
C. Niaje                      D. Sema

**22.** Zuri alionyesha hisia zipi kwa rafiki yake?

- A. Hasira na kero  
B. Mshangao na kejeli  
C. Huruma na faraja  
D. Hofu na woga.

**23.** Kulingana na kifungu, Zuri alihisi vipi baada ya mazungumzo na Ashton?

- A. Alijuta na kukasirika zaidi  
B. Alisisitiza kuwa hawezi tena kusoma  
C. Alifurahi na kuamua kujaribu tena  
D. Alikataa ushauri na akaondoka.

**24.** Ni tabia ipi nzuri ya mawasiliano imeonyeshwa katika mazungumzo haya?

- A. Kukosoa mtu kwa kushindwa  
B. Kusikiliza na kutoa msaada wa kihisia  
C. Kucheka hali ya mwingine  
D. Kutojali hisia za wengine.

**25.** Chagua nahau inayofaa kujaza nafasi ya 25 katika kifungu?

- A. Tembea polepole  
B. Pambana na hali yako  
C. Jibane mkanda  
D. Simama kidete.

**Kifungu kifuatacho kina nafasi 26 hadi 40. Umepewa majibu manne hapo chini, chagua jibu lifaalo zaidi kujaza nafasi.**

Je, umewahi kujiuliza \_\_\_26\_\_\_ wadudu \_\_\_27\_\_\_ mchwa wanavyoishi? Wadudu \_\_\_28\_\_\_ huishi katika makundi. Katika \_\_\_29\_\_\_ hiyo, utampata malkia ambaye \_\_\_30\_\_\_ lake ni \_\_\_31\_\_\_ tu! Katika jamii hiyo \_\_\_32\_\_\_, utawapata walinzi \_\_\_33\_\_\_ kazi yao muhimu ni kuulinda \_\_\_34\_\_\_ wa jamii nzima. Panapotokea uvamizi, wao hujitokeza \_\_\_35\_\_\_ na kuuma maadui \_\_\_36\_\_\_ ukali kweli. Pia kuna \_\_\_37\_\_\_ ambao hutayarisha kichuguu. Nao hutumia \_\_\_38\_\_\_ mkubwa sana. Kichuguu hicho hujengwa \_\_\_39\_\_\_ na vyumba mbalimbali \_\_\_40\_\_\_ wakitumia udongo na mate pekee.

- |                  |            |                |                  |
|------------------|------------|----------------|------------------|
| 26. A. vile vile | B. aina    | C. walivyo     | D. jinsi         |
| 27. A. akina     | B. waitwao | C. hao         | D. kama          |
| 28. A. huyo      | B. kama    | C. hawa        | D. wale          |
| 29. A. vikundi   | B. hundi   | C. mikusanyiko | D. makundi       |
| 30. A. jukumu    | B. kazi    | C. nia         | D. haja          |
| 31. A. uzao      | B. kuzaa   | C. uzalishaji  | D. huzaa         |
| 32. A. hiyo      | B. hii     | C. iyo         | D. ile           |
| 33. A. ambazo    | B. ambamo  | C. ambaye      | D. ambao         |
| 34. A. salama    | B. amani   | C. usalama     | D. umoja         |
| 35. A. tayari    | B. kivita  | C. ugomvi      | D. hiari         |
| 36. A. kwa       | B. wa      | C. kuwa        | D. na            |
| 37. A. wajuzi    | B. ujenzi  | C. wajenzi     | D. watengenezaji |
| 38. A. mjusi     | B. ujuzi   | C. ujusi       | D. mjuzi         |
| 39. A. ukiwa     | B. vikiwa  | C. kikiwa      | D. wakiwa        |
| 40. A. wakiwa    | B. humo    | C. na          | D. huku          |

**Jibu swali la 41 hadi la 50, kulingana na maagizo uliyopewa.**

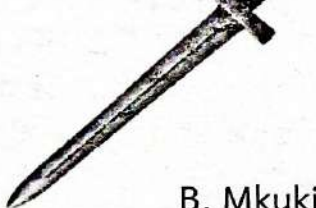
41. Chagua nomino ya pekee.  
A. Afrika                      B. Kiti  
C. Shamba                     D. Mto
42. Chagua pambo huvaliwa mkononi  
A. Kipuli                        B. Mapete  
C. Bangili                       D. Kidani
43. Chagua sentensi iliyoakifishwa vyema.  
A. Shabash? Mbona ukaruka nje  
B. Je, ulimkuta akifanya nini?  
C. Kumbe! Aliwasili mapema  
D. Kwa nini hukumpokea.
44. Maneno "**ugonjwa**" na "**ubele**" huorodheshwa katika ngeli ipi?  
A. LI - YA                        B. U - ZI  
C. U - U                            D. U - YA
45. Kipi ni kitenzi kikuu katika sentensi ifuatayo? Shangazi alikuwa akipika chakula jikoni.  
A. shangazi                      B. alikuwa  
C. akipika                         D. chakula
46. **Tegua kitendawili kifuatacho;**  
Mfalme wetu hushuka kwa kelele.  
A. Mvua  
B. Usingizi  
C. Mwangwi  
D. Baridi.
47. Tambua kifaa hiki.
- 
48. Andika sentensi ifuatayo katika usemi wa taarifa:  
**"Sitacheza kesho" Nelima alisema**  
A. Nelima alisema hatacheza siku itakayofuata.  
B. Nelima alisema kuwa hangecheza siku iliyofuata  
C. Sitacheza kesho alisema Nelima  
D. Nelima alisema kuwa hatacheza kesho.
49. Kinyume cha "**Milka hushona nguo**" ni  
A. Nguo hushonwa na Milka  
B. Milka hushonwa nguo  
C. Hashoni nguo Milka  
D. Milka hashoni nguo.
50. Katika kamusi, neno ambalo litaandikwa kabla ya neno "**kafiri**" lakini baada ya neno "**kafala**" ni  
A. Kifaru                         B. Kaptura  
C. Kafara                         D. Kafua



2. **ZOEZI LA II: FASIHI SIMULIZI.(ALAMA 10)**

**Soma taarifa ifuataye kisha ujibu maswali**

Usalama ni uwepo wa amani bila tishio wala hatari yoyote: Kila mmoja hupenda kukaa palipo na usalama.

Mtoto akiwekwa katika hali ya vurugu maisha yake huathirika vibaya. Yeye hukosa kujiamini na akiwa mbele ya watu hugeuka bubu. Ni rahisi kumtambua mtoto kama huyu shuleni. Mara nyingi hujitenga na shughuli wanazoshiriki wenzake hasa mchezo, majadiliano na shughuli za vyama vya wanafunzi shuleni. Isitoshe pia kukosa kujiamini na kujieleza ipasavyo.

Ni muhimu kuelewa kuwa wakati mwingine, matendo ya mtu yanaweza kumsababishia utovu wa usalama. Mifano ni wale wanaojipalia makaa kwa kudandia magari yapitayo kwa kasi, kuchezea karibu na barabara au viziwa vya maji. Wengine huchezeana michezo inayowaweka katika hatari ya kujeruhiana.

Jukumu la kudumisha usalama halifai kuachiwa wazazi na walezi pekee. Lazima tujaliane maslahi popote tulipo. Ukihisi kwamba unakabiliwa na tishio la aina yoyote; mjulishe mzazi, mwalimu au mtu mzima unayemthamini.

(a) Eleza maana ya usalama.

(a1)

- (b) Ni jambo gani itafanyika kwa mtoto aliyelelewa kwa vurugu? (a12)
- (i) \_\_\_\_\_
- (ii) \_\_\_\_\_
- (c) Taja shughuli tatu ambazo mtoto anayelelewa kwa vurugu atajitenga nazo katika shule. (a13)
- (i) \_\_\_\_\_
- (ii) \_\_\_\_\_
- (iii) \_\_\_\_\_
- (d) Ni mambo yapi ambayo ni tishio kwa usalama wa mtoto? (a13)
- (i) \_\_\_\_\_
- (ii) \_\_\_\_\_
- (iii) \_\_\_\_\_
- (e) Msemo kujipalia makaa umetumika katika kifungu. Maana yale ni (a12)
- (i) \_\_\_\_\_
- (ii) \_\_\_\_\_
- (iii) \_\_\_\_\_
- (f) Ni jukumu la nani kudumisha usalama? (a1)
- \_\_\_\_\_
- \_\_\_\_\_

### **Zoezi III:Novella (Alama 10)**

#### **3. Soma sehemu ifuatayo ya novela kisha ujibu maswali.**

Usiku huo, kwa mara ya kwanza tangu jahazi la elimu ya Herina kugonga mwamba, Herina aliwasiliana na ndugu zake. Aliwaambia kwamba walihitaji kutafuta muda wa kumtembelea mama yao. Usiku huo, Herina, alimpigia mama yake simu. Alimhakikishia kwamba angefanya kazi kwa bidii ili awe kiumbe wa kutegemewa.

Herina alipata usingizi wa pono, jambo ambalo si la kawaida kwa mtu ambaye alikabiliwa na dhiki kama yake. Hakujua vipi lakini aliyapata macho yake yamesalimu amri mara tu kichwa chake kilipogusana na foronya ya mto wa kitanda chake. Kinyume cha siku nyingine, usiku huo hakuwa na ndoto nyingi isipokuwa moja tu. Ndoto hiyo ilimshangaza sana. Alimwona shangazi akiwa na babu yake. Dina alikuwa ameshika mkono wa kulia. Shangazi alimvuta Herina upande wake huku baba yake akimvuta upande wake. Wawili hawa walionekana kama makundi mawili ambayo yalikuwa yanacheza jugwe. Katika hali hii. Herina alihisi baba yake akimvuta kwa nguvu zaidi huku shangazi akilemewa. Herina alianza kupoteza fahamu na hatimaye akazimia. Alipozinduka alijipata nyumbani kwao kijijini, ubavuni ameketi kwenye kiti chake cha kawaida akiwa ameshika mkongojo kwenye mkono wa kulia.

Herina aliamshwa na sauti ya mwadhini wa msikiti uliokuwa karibu. Aliamka na kuketi kwenye kochi lililokuwa chumbani humo. Alifanya sala yake ya alfajiri kisha akafanya mazoezi ya viungo mumo humo chumbani. Hakutaka kukimbia kwa vile haya yalikuwa mazingira mageni.

- (a) Eleza mbinu za lugha zilizotumiwa katika sehemu hii ya novela (a12)

- (b) Eleza aina mbili za mandhari zinazojitokeza katika sehemu hii ya Novela (a12)  
 (i) \_\_\_\_\_  
 (ii) \_\_\_\_\_
- (c) Herina ni mkakamavu. Eleza sifa nyingine za Herina. (a12)  
 (i) \_\_\_\_\_  
 (ii) \_\_\_\_\_
- (d) Tambua na kueleza masuala mawili yanayo shughulikiwa katika sehemu hii ya novela (a12)  
 (i) \_\_\_\_\_  
 (ii) \_\_\_\_\_
- (e) Eleza mfuatano wa matukio katika sehemu hii ya novela. (a12)  
 \_\_\_\_\_  
 \_\_\_\_\_

**Zoezi la IV:USHAIRI (Alama 10)**

**4. Soma shairi lifuatalo kisha ujibu maswali.**

Hapa naanza kauli, kulemsha tahadhari,  
 Kumejaa baradhuli, wasije kutuathiri,  
 Haja yao ni vigoli, wasiomaizi dhamiri,  
 Kumezidi si kathriti, ubakaji watudhili.

Hawatambui aili, hukosa na tahadhari,  
 Kila njama na fiili, huzitumia kwa biri,  
 Banati hata rijali, wengine huwaathiri  
 Kumezidi si kathiri, ubakaji watudhili.

Wengine kwa ukatili, huku wakijifahiri,  
 Hujitia kutojali, ja utendavyo bakari,  
 Hukosa na taamuli, ayali kuwakasiri,  
 Kumezidi si kathiri, ubakaji watudhili.

- (a) Shariri hili ni la muundo upi? (a12)  
 (i) \_\_\_\_\_  
 (ii) \_\_\_\_\_
- (b) Shairi hili lina beti ngapi (a11)  
 \_\_\_\_\_
- (c) Mshororo wa nne wa shairi hili huitwaje? (a11)  
 \_\_\_\_\_
- (d) Taja vina vya kati na vya mwisho vya shairi hili (a12)  
 \_\_\_\_\_
- (e) Kila mshororo una mizani ngapi? (a12)  
 \_\_\_\_\_

# KENYA JUNIOR SCHOOL EDUCATION ASSESSMENT GRADE 9 - YEAR 2026



001

## AGRICULTURE

Name \_\_\_\_\_ Assessment No. \_\_\_\_\_

School \_\_\_\_\_ Date. \_\_\_\_\_

Instructions: This paper consists of two sections A and B

TIME: 1HR. 40MIN

### SECTION A : (15 MARKS)

1. The following are causes of soil pollution.

Which one is **not**?

- A. Excessive use of inorganic fertilizers
- B. Excessive use of organic fertilizers
- C. Poor disposal of plastic wastes
- D. Use of agricultural chemicals

2. Which of the following is **not** a minimum tillage practice?

- A. Mulching
- B. Uprooting or slashing
- C. Weeding
- D. Use of herbicides

3. The following are uses of agro-forestry trees **except**

- A. trees provide timber for building structures
- B. trees draw water and nutrients from deep in the ground
- C. tree build soil organic matters through shedding leaves
- D. trees provide pasture and shelter for livestock

4. Which of the following is **not** a method of conserving the soil?

- A. to protect some farm structures
- B. to enable efficient use of farm structures
- C. to increase cost of maintaining soil fertility
- D. to prevent loss of soil nutrients

5. The diagram below shows a type of soil conservation.

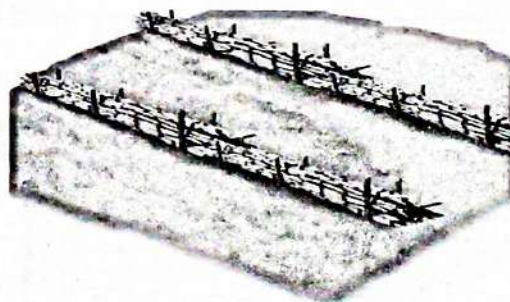

Identify the above structure.

- A. Stone lines
- B. Grassed water way
- C. Strip cropping
- D. Trash lines

6. Mr. Onsongo, a nutrition teacher, was teaching his learners factors determining a cooking method. Which one is **not**?

- A. Flavour
- B. Time
- C. Fuel
- D. Equipment

7. Grade 7 learners from Imani Academy were collecting materials used in laundering loose - coloured clothes. Which one of the following materials was **not** collected?
- Vinegar
  - Bleaching agent
  - Salt
  - Lemon
8. Patome was researching on methods of adding value to crop produce. Which of the following is a method of adding value to crops?
- Storing
  - Harvesting
  - Drying
  - Boiling
9. The diagram below represents one of the water retention structures used in agricultural production.



Identify the structure above.

- Water retention ditches
- Sunken bed
- Earth basin
- Water retention pits

10. Which of the following is **not** an example of an innovative kitchen garden?
- Container
  - Multi-storey
  - Seedbed
  - Wick
11. Achieng was tasked to find out practices that ensure vegetables retain their nutrients during cooking? Which one of the following is such a practice?
- Cutting before washing
  - Boiling for a long time
  - Steaming vegetables
  - Using excessive water
12. Using a poultry fold to rear poultry has advantages and disadvantages. Which one of the following is a disadvantage?
- They are portable
  - They require regular cleaning
  - They protect bird from predators
  - They allow birds to access fresh vegetation
13. Which of the following methods is effective in controlling pests?
- Over watering the crops
  - Handpicking pest
  - Allowing crops to fry out
  - Planting crops too close together
14. What is the **best** method to prevent contamination of honey during processing?
- Using dirty tools
  - Storing honey in air tight containers
  - Using muslin cloth that is clean
  - Leave the combs unprocessed

15. Which of the following vegetables requires fine tilth during planting?
- A. Maize
  - B. Potatoes
  - C. Millet
  - D. Bananas

**Section B : (35 MARKS)**

**Answer all the questions in the spaces provided.**

16. (a). Define thinning in crop production. (2mks)

\_\_\_\_\_

\_\_\_\_\_

- (b). Explain the importance of thinning in maize production. (3mks)

(i). \_\_\_\_\_

(ii). \_\_\_\_\_

(iii). \_\_\_\_\_

- 17.(a). A nutritionist interacted with a group of learners and discussed factors to consider when preparing a balanced meal. State **four** factors that they may have discussed (4mks)

(i). \_\_\_\_\_

(ii). \_\_\_\_\_

(iii). \_\_\_\_\_

(iv). \_\_\_\_\_

- (b). After preparing a balanced meal one has a choice to serve it using different serving styles. Identify **two** serving styles and explain the difference between them. (4mks)

(i). \_\_\_\_\_

\_\_\_\_\_

(ii). \_\_\_\_\_

\_\_\_\_\_

18. A resource person visited Grade 8 learners in Akili Junior School for a lesson on preserving milk and meat. State **two** possible importance of the practice they discussed. (2mks)

(i). \_\_\_\_\_

(ii). \_\_\_\_\_

(iii). \_\_\_\_\_

19. An agricultural officer gave a speech to Kilimo Young Farmers on services they can access using ICT. Suggest **five** possible sources they discussed. (5mks)

- (i). \_\_\_\_\_
- (ii). \_\_\_\_\_
- (iii). \_\_\_\_\_
- (iv). \_\_\_\_\_
- (v). \_\_\_\_\_

20. Onditi watched a documentary on challenges with animal waterers used in the community. State **five** possible challenges. (5mks)

- (i). \_\_\_\_\_
- (ii). \_\_\_\_\_
- (iii). \_\_\_\_\_
- (iv). \_\_\_\_\_
- (v). \_\_\_\_\_

21. Matora wants to put surface run off into good use.

(a). Define the term surface run-off. (2mks)

\_\_\_\_\_

\_\_\_\_\_

(b). State **three** ways he can use the surface run-off (3mks)

- (i). \_\_\_\_\_
- (ii). \_\_\_\_\_
- (iii). \_\_\_\_\_

22. (a). Explain the meaning of the terms below. (3mks)

(i). Mopping

\_\_\_\_\_

\_\_\_\_\_

(ii). Dusting

\_\_\_\_\_

\_\_\_\_\_

(b). List **three** routine daily cleaning practices in the kitchen. (3mks)

- (i). \_\_\_\_\_
- (ii). \_\_\_\_\_
- (iii). \_\_\_\_\_

## GRADE 9 - YEAR 2026 SOCIAL STUDIES



001

Name \_\_\_\_\_

Assessment No. \_\_\_\_\_

School \_\_\_\_\_

Date \_\_\_\_\_

Instructions: This paper consists of two Sections A and B

TIME: 1HR. 30MIN

### SECTION A: (20 MARKS)

- Identify the **main** reason for conserving historical sites.  
A. To prevent population growth  
B. To preserve cultural heritage  
C. To build modern facilities  
D. To promote communication
- Grade 9 learners of Salama Junior School were discussing the effects of overpopulation in Africa. Which one of the following is **correct**?  
A. Increase in job opportunities  
B. Improvement of health facilities  
C. Growth of forests  
D. Strain on resources
- The following are elements of a good map **except**  
A. school                      B. key  
C. scale                         D. frame
- A family that shows love, care and cooperation is **best** described as  
A. a blended family  
B. a nuclear family  
C. a peaceful family  
D. an extended family
- Which relief feature is **correctly** matched with its description?  
A. **Plateau** - A narrow strip of lowland  
B. **Mountain** - A high land with steep slopes  
C. **Rift valley** - A raised block of land  
D. **Plain** - A steep-sided depression

- Name the theory that explains how human beings gradually developed from simple form of life into complex one.  
A. Mythical theory  
B. Creation theory  
C. Nebular theory  
D. Evolution theory
- The **best** way to resolve conflicts peacefully is by  
A. negotiation and mediation  
B. mob justice  
C. ignoring issues  
D. fighting to win
- Which of the following explains why citizens pay taxes to the governments.  
A. To bribe the leaders  
B. Citizens can be rewarded  
C. To enable the government to deliver services  
D. To be seen by other citizens
- The diagram below shows a volcanic mountain

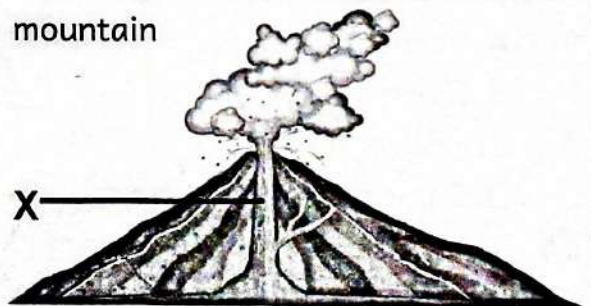

- The part marked X is known as
- dyke
  - vent
  - crater
  - conelet

10. The following methods are used to represent relief features on topographic maps **except** one. Which one is it?

- A. contours
- B. hill shading
- C. spots height
- D. swamp

11. Three of the following are ways of maintaining and improving one's social life **except**

- A. not interacting with people to prevent conflicts
- B. joining clubs or community groups to meet new people
- C. showing kindness towards other
- D. maintaining good relationships with people

12. People who take drugs and alcohol may experience different health problems. Which one of these is **correct**?

- A. High blood pressure
- B. Sleeplessness
- C. Self-control
- D. Heart attack

13. Grade 9 learners were discussing types of earth movements. Which of the following types they listed was **not** correct?

- A. Vertical
- B. Shear
- C. Horizontal
- D. Convectional currents

14. The constitution of Kenya is made up of 18 chapters. Which chapter contains the bill of rights?

- A. 17
- B. 4
- C. 1
- D. 10

15. According to the theory of continental drift the earth was once a single continent known as

- A. Pangaea
- B. Panthalasa
- C. Laurasia
- D. Gondwana land

16. Which of the following countries colonized Senegal during the scramble and partition of Africa?

- A. Britain
- B. Germany
- C. France
- D. Italy

17. The weather instrument below is known as

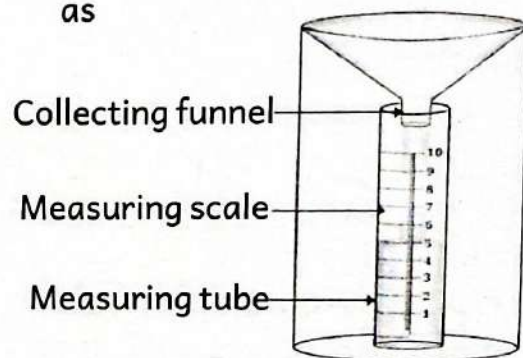

- A. windsock
- B. hygrometer
- C. thermometer
- D. raingauge

18. Which of the following is a quality of a good citizen?

- A. Dishonest
- B. Team builder
- C. Lazy
- D. Rude

19. The following are important values in problem solving through critical thinking **except**

- A. social injustices
- B. patience
- C. respect
- D. responsibility

20. Which of the following is **not** a component of the constitution of Kenya?

- A. Schedules
- B. Manifestos
- C. Chapters
- D. Preamble

**SECTION B: (30 MARKS)**

**Answer all the questions in the spaces provided.**

21. Grade Eight learners of Tabibu Junior School were provided with the sketch map of Inuka area drawn below to carry out map reading and interpretation. Use it to answer the questions that follow.

**INUKA AREA**

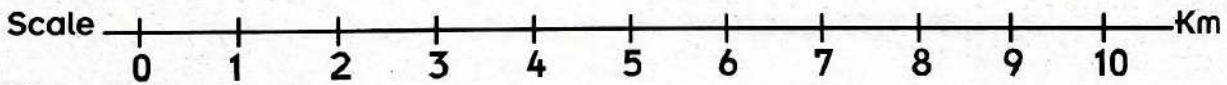
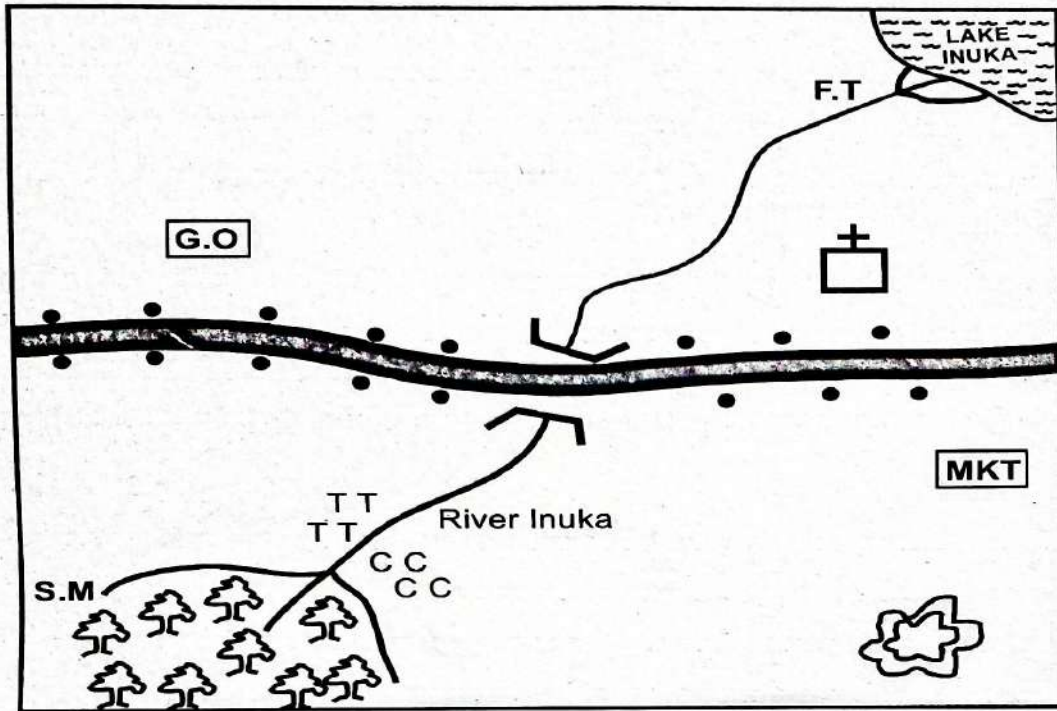

Key:

	Tarmac road		Church	<b>F.T</b>	Fish trap	<b>SM</b>	Sawmill
	Houses	<b>TT</b>	Tea		Quarry	<b>G.O</b>	Governor's office
	Forest	<b>CC</b>	Coffee	<b>MKT</b>	Market		

- (a). Which type of settlement pattern is found in Inuka area? (1mk)
- \_\_\_\_\_
- (b). What is the direction of the forest from the lake. (1mk)
- \_\_\_\_\_
- (c). Identify **four** economic activities carried out in Inuka area. (4mks)
- (i). \_\_\_\_\_
- (ii). \_\_\_\_\_
- (iii). \_\_\_\_\_
- (iv). \_\_\_\_\_
- (d). Inuka area is **likely** to be headed by. (1mk)
- \_\_\_\_\_

(e). The residents of Inuka area are likely to belong to which religion? (1mk)

(f). Describe the climatic condition of the area surrounded by the forest. (1mk)

22. Grade Nine learners were asked by their Social Studies teaches to list down the **three** pathways they are **likely** to choose when joining senior school. Give the **correct** response they listed. (3mks)

(i). \_\_\_\_\_

(ii). \_\_\_\_\_

(iii). \_\_\_\_\_

23. State **three** causes of earth movement. (4mks)

(i). \_\_\_\_\_

(ii). \_\_\_\_\_

(iii). \_\_\_\_\_

24. Grade 9 learners were discussing the qualities of a global citizen. List **four** qualities they gave. (4mks)

(i). \_\_\_\_\_

(ii). \_\_\_\_\_

(iii). \_\_\_\_\_

(iv). \_\_\_\_\_

25. Mr. Mshindi invited a resource person to give a talk to Grade 9 learners on diversity and interpersonal skills.

(a). What are personal skills. (2mks)

\_\_\_\_\_

\_\_\_\_\_

(b). Give **two** ways of managing peer pressure. (2mks)

(i). \_\_\_\_\_

(ii). \_\_\_\_\_

26. List **two** methods used in representing physical features on topographical maps. (2mks)

(i). \_\_\_\_\_

(ii). \_\_\_\_\_

27. Grade 9 learners watched a documentary on sustainable use of resources.

(a). What is a resources? (2mks)

\_\_\_\_\_

\_\_\_\_\_

(b). Give **two** examples of resources found in our country. (2mks)

(i). \_\_\_\_\_

(ii). \_\_\_\_\_

# KENYA JUNIOR SCHOOL EDUCATION ASSESSMENT GRADE 9 - YEAR 2026



STEP FLYER

001

## CREATIVE ARTS & SPORTS

Name \_\_\_\_\_

Assessment No. \_\_\_\_\_

School \_\_\_\_\_

Date \_\_\_\_\_

Instructions: This paper consists of two sections: A and B

TIME: 1HR. 40MIN

### SECTION A: (20 MARKS)

1. Mwomboko is a folk dance performed by the \_\_\_\_\_ community.

- A. Kipsigis
- B. Kikuyu
- C. Luyha
- D. Abakuria

2. Study the following music symbol and identify its name.



- A. Treble clef
- B. G clef
- C. Bass clef
- D. Semibreve clef

3. The following are elements of a story. Which one is **not**?

- A. Plot
- B. Persona
- C. Setting
- D. Theme

4. An accidental that lowers the pitch of the note is known as

- A. key signature
- B. dot
- C. flat
- D. sharp

5. Which of the following races is a middle distance race?

- A. 400m
- B. 200m
- C. 3000m
- D. 800m

6. Study the following item made using the pottery technique and identify the method used to decorate it.



- A. Incising
- B. Stamping
- C. Burnishing
- D. Smoking

7. Some Grade 9 learners made vases using the pottery technique. Identify the one who used an appropriate drying method.

- A. Okenyuri - Dried under the shade
- B. Bitengo - Dried in an oven
- C. Ochieng' - Dried under the sun
- D. Muthoni - Dried in a pit filled with hot coals

8. How many players make a team in a game of netball?

- A. 8
- B. 7
- C. 6
- D. 11

9. Study the following facility and identify the game played there.

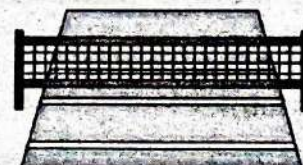

- A. Netball
- B. Handball
- C. Volleyball
- D. High jump

10. The act of starting play in a game of volleyball by hitting the ball into the opponent's court is known as

- A. passing
- B. striking
- C. service
- D. dribbling

11. Identify the player who is allowed to use their hands in a game of football.

- A. Referee
- B. Strikers
- C. All players
- D. Goalkeeper

12. When performing a melody using the descant recorder, Teya partially covered the thumb hole leaving some space. Identify the descant recorder playing technique he was executing.

- A. Embouchure
- B. Slurring
- C. Pinching
- D. Fingering

13. The following are materials used in the basketry technique. identify one that is **not**.

- A. Banana fibre
- B. Raffia
- C. Plastic cuttings
- D. Sisal

14. Which of the following is the last phase in a javelin throw?

- A. Follow through
- B. Landing
- C. Cross over
- D. Approach run

15. Study the following image and identify the name of the items on display.



- A. Relay batons
- B. Marking cones
- C. Finish line tape
- D. Rounders base

16. When performing the Maasai dance, the Grade Seven learners tied the Maasai shukas as the maasai people do. This type of clothing is known as

- A. costumes
- B. dancing clothes
- C. the maasai clothing
- D. traditional clothes

17. Study the following drawing.

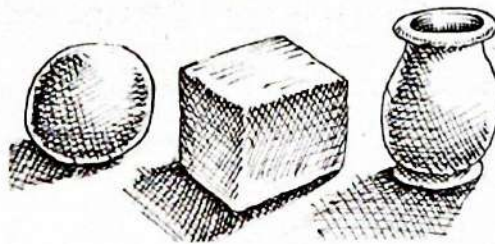

Identify the drawing technique used to create tonal value in the drawing above.

- A. Stippling
- B. Crosshatching
- C. Lines
- D. Shading

18. Which of the following is an element of photography?

- A. Colour
- B. Layout
- C. Lighting
- D. Camera

19. Study the following Kodaly hand sign and identify the solfa syllable that corresponds with it.

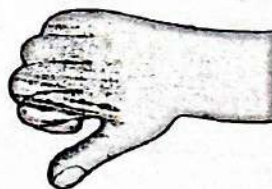

- A. Do
- B. Fa
- C. Mi
- D. Ti

20. The following are values that we learn through sporting. Which one is **not**?

- A. Teambuilding
- B. Cheering
- C. Equality
- D. Fairness

**SECTION B: 30 MARKS**

**Answer all the questions in the space provided.**

21. List **three** elements of verse. (3mks)

- (i). \_\_\_\_\_
- (ii). \_\_\_\_\_
- (iii). \_\_\_\_\_

22. List **three** activities that enhance endurance. (3mks)

- (i). \_\_\_\_\_
- (ii). \_\_\_\_\_
- (iii). \_\_\_\_\_

23. On the space provided below, compose a 4 bar rhythm in  $\frac{3}{4}$  time. (4mks)

24. Describe how the note of **G** is played using the descant recorder. (5mks)

---

---

---

---

---

25. On the space provided below, draw **three** shapes and indicate overlapping and balance of forms. (4mks)

26. List **three** social roles of creative arts and sports. (3mks)

- (i). \_\_\_\_\_
- (ii). \_\_\_\_\_
- (iii). \_\_\_\_\_

27. Study the following images and identify the athletic event and technique being executed. (2mks)

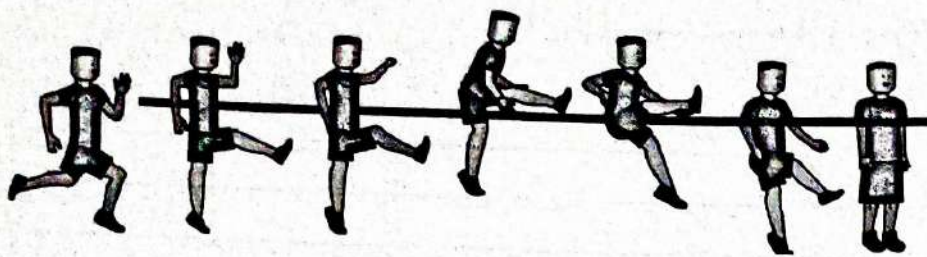

(i). Event

(ii). Technique

28. List two sound devices used in a verse. (2mks)

(i).

(ii).

### OPTIONAL SECTION

Answer either question 29 or 30

29. **Swimming:**

(a). List two leg movements executed by the swimmer in the water treading technique. (2mks)

(i).

(ii).

(b). List two swimming pool hygiene precautions that should be adhered to when swimming. (2mks)

(i).

(ii).

30. **Indigenous games.**

(a). Define indigenous tagging games. (2mks)

(b). Identify an indigenous tagging game played in your community. (2mks)

# KENYA JUNIOR SCHOOL EDUCATION ASSESSMENT

## GRADE 9 - YEAR 2026

### RELIGIOUS EDUCATION

TIME: 1HR. 20MIN



001

Name \_\_\_\_\_

Assessment No. \_\_\_\_\_

School \_\_\_\_\_

Date \_\_\_\_\_

Instructions: This paper consists of C.R.E and I.R.E

#### CHRISTIAN RELIGIOUS EDUCATION SECTION A: (20 MARKS)

- From the Genesis stories of creation, human beings are the most important of God's creation because
  - God put them in charge of animals and plants
  - they were given the garden of Eden
  - they were made in the image of God
  - they were made male and female
- According to Christians teaching, God is all knowing. This attribute of God is called
  - eternal
  - omnipresent
  - omnipotent
  - omniscient.
- Who was the son of Abraham through whom God's covenant promises were continued?
  - Ishamel
  - Isaac
  - Jacob
  - Esau
- Which among the following skills is needed to help young people examine and analyse information before taking action?
  - Decision making
  - Self awareness
  - Critical thinking
  - Creative thinking
- During a CRE lesson, Grade 8 learners discussed different categories of the books of the Bible. Choose the book of the Bible that is put in the **right** group

<u>Book</u>	<u>Group</u>
A. Genesis	Prophetic
B. Jeremiah	Law
C. Revelation	Gospel
D. Acts	Historical
- What was the sign of the covenant between God and Abraham?
  - Rainbow
  - Circumcision
  - Blood
  - Cloud
- During a CRE lesson, you discussed different parables of Jesus. The parable which teaches about the growth of kingdom of God is the parable of
  - The Good Samaritan
  - The Mustard Seed
  - The Lost Sheep
  - The Friend at Midnight.
- Which prophet prophesied the end of Saul's rule?
  - Samuel
  - Elisha
  - Elijah
  - Nathan
- Conflict refers to a state of disagreement between people. Which one is **not** a cause of conflict in families?
  - Personality differences
  - Poor communication
  - Negative peer pressure
  - Proper use of family resources.
- Jesus taught his disciples to pray using a specific prayers pattern. This is known as
  - the prayer of faith
  - the Lord's prayer
  - the disciples' prayer
  - the high priestly prayer.

**SECTION B: (30 MARKS)**

**Answer all the questions in the space provided.**

**11.** A teacher assigned your class to outline leadership qualities you can emulate from Moses. State **five** points that you heard. (5mks)

- (i) \_\_\_\_\_
- (ii) \_\_\_\_\_
- (iii) \_\_\_\_\_
- (iv) \_\_\_\_\_
- (v) \_\_\_\_\_

**12.** List **five** causes of early pregnancies among the teenage girls in Kenya today. (5mks)

- (i) \_\_\_\_\_
- (ii) \_\_\_\_\_
- (iii) \_\_\_\_\_
- (iv) \_\_\_\_\_
- (v) \_\_\_\_\_

**13.** A resource person has visited your school and the topic of discussion is sexual abuse. Name **three** forms of sexual abuse the resource person is likely to mention. (3mks)

- (i) \_\_\_\_\_
- (ii) \_\_\_\_\_
- (iii) \_\_\_\_\_

**14.** Grade 8 learners discussed how Abraham demonstrated his faith in God. Outline **five** points that they came up with. (5mks)

- (i) \_\_\_\_\_
- (ii) \_\_\_\_\_
- (iii) \_\_\_\_\_
- (iv) \_\_\_\_\_
- (v) \_\_\_\_\_

**15.** Identify **five** main causes of conflict in modern families today. (5mks)

- (i) \_\_\_\_\_
- (ii) \_\_\_\_\_
- (iii) \_\_\_\_\_
- (iv) \_\_\_\_\_
- (v) \_\_\_\_\_

**16.** Your class brainstormed on lessons learned from the failures of king Saul. Identify **five** points that you found out. (5mks)

- (i) \_\_\_\_\_
- (ii) \_\_\_\_\_
- (iii) \_\_\_\_\_
- (iv) \_\_\_\_\_
- (v) \_\_\_\_\_

17. Give **two** examples of people with diverse needs in the community (2mks)

(i) \_\_\_\_\_  
(ii) \_\_\_\_\_

18. Prayer is an act of communication with God. List down **five** importance of prayer. (5mks)

(i) \_\_\_\_\_  
(ii) \_\_\_\_\_  
(iii) \_\_\_\_\_  
(iv) \_\_\_\_\_  
(v) \_\_\_\_\_

### **ISLAMIC RELIGIOUS EDUCATION**

#### **SECTION A: (20 MARKS)**

1. The first revelation of the prophet Muhammad (S.A.W) was received at;  
A. Mount Arafah  
B. Mount Safa  
C. Cave of Hira  
D. Cave Thawr
2. According to Islam, Hijrah marked the beginning of  
A. the construction of Kaaba  
B. the Islamic calendar  
C. the battle of Badr  
D. the revelation of Quran
3. The prophet who was commanded to slaughter his son in a dream was  
A. prophet Nuh (A.S)  
B. Prophet Yusuf (A.S)  
C. Prophet Ibrahim (A.S)  
D. Prophet Issac (A.S)
4. The term "shirk" means  
A. honesty  
B. associating partners with Allah  
C. Truthfulness  
D. Kindness
5. The Islamic practice of helping the needy voluntarily is known as  
A. Zakat  
B. Sadaqah  
C. Swalah  
D. Saum
6. The surah that emphasizes the importance of time is  
A. L-Kauthar  
B. Al-Ikhlās  
C. Al-Asr  
D. Al-Falaq
7. The term Akhirah refers to  
A. the world  
B. death  
C. the life after death  
D. the day of judgment
8. The battle of Badr was fought in the year of  
A. 1 A.H  
B. 2.A. H  
C. 3. A. H  
D. 4 A. H
9. The prophet who interpreted dreams while in prison was  
A. Yunus (A.S)  
B. Yusuf (A.S)  
C. Ayub (A.S)  
D. Dawud (A.S)
10. The pillar of Islam that unites Muslims all over the world is  
A. Swalah  
B. Zakat  
C. Hajj  
D. Shahad

**SECTION B: (30 MARKS)**

**11. State two reasons why Muslims perform Hajj** (2mks)

(i) \_\_\_\_\_

(ii) \_\_\_\_\_

**12. Give any two qualities of the prophet that you learnt** (2mks)

(i) \_\_\_\_\_

(ii) \_\_\_\_\_

**13. Outline two benefits of zakat to the Muslims community.** (2mks)

(i) \_\_\_\_\_

(ii) \_\_\_\_\_

**14. Mention two ways of showing respect to the Quran.** (2mks)

(i) \_\_\_\_\_

(ii) \_\_\_\_\_

**15. Discuss two characteristics of a good Muslim.** (2mks)

(i) \_\_\_\_\_

(ii) \_\_\_\_\_

**16. List five pillars of Islam in their correct order.** (5mks)

(i) \_\_\_\_\_

(ii) \_\_\_\_\_

(iii) \_\_\_\_\_

(iv) \_\_\_\_\_

(v) \_\_\_\_\_

**17. Write two teachings learnt from surah Humazah.** (2mks)

(i) \_\_\_\_\_

(ii) \_\_\_\_\_

**18. Mention two ways Muslims can promote peace in the community.** (2mks)

(i) \_\_\_\_\_

(ii) \_\_\_\_\_

**19. Explain one reason why Muslims should avoid shirk.** (2mks)

\_\_\_\_\_

\_\_\_\_\_

# KENYA JUNIOR SCHOOL EDUCATION ASSESSMENT

## GRADE 9 - YEAR 2026

### PRE-TECHNICAL STUDIES



001

Name \_\_\_\_\_

Assessment No. \_\_\_\_\_

School \_\_\_\_\_





Date \_\_\_\_\_

**Instructions:** This paper consists of two Sections A and B

**TIME: 1HR. 40MIN**

#### SECTION A : (15 MARKS)

1. Grade 8 learners at Kisii Campus Junior School were discussing composite materials. Which among the following is a composite material?

A.		Glass
B.		Concrete
C.		Steel
D.		Aluminium

2. Which one of the following is a safety hazard in the workshop?
- Tools on the floor
  - Wearing safety goggles
  - Good lighting
  - Proper ventilation
3. Learners were asked by their teacher to discuss the importance of saving money. Which among the following is the importance?

- You have funds for future needs and emergencies
  - It increases your expenses
  - You can spend money immediately
  - It makes you poor
4. Which among the following practices is an unethical practice by a seller towards a consumer?
- Product accurate information
  - Selling goods at fair price
  - Selling expired good
  - Issuing customers with vouchers
5. Grade 9 learners were discussing computer hardware components. Which among the following is a hardware component of a computer?
- Microsoft word
  - Keyboard
  - Operating system
  - Internet browser
6. Learners were asked by their teacher to discuss the main function of the CPU. Which answer did they get?
- To display images
  - To store data
  - To perform calculations
  - To print documents

7. Which of the following is a source of business idea?
- A. Saving money
  - B. Paying taxes
  - C. Hiring staff
  - D. Identifying problems of unsatisfied customers

8. Learners were asked to draw a line that represents a cutting plane. Which one did they draw?

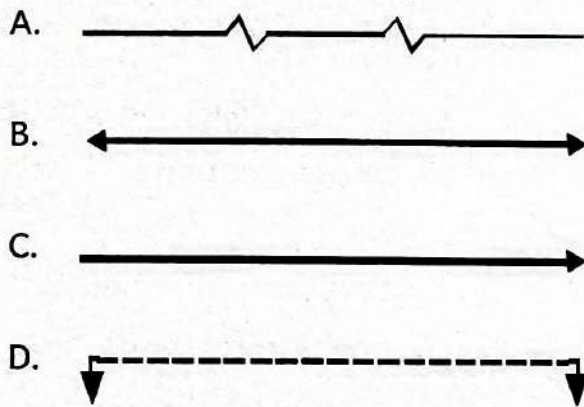

9. Grade 9 learners used the following devices to perform tasks. Which one was the **odd** one out.
- A. Desktop computer
  - B. Smartphone
  - C. Mainframe computer
  - D. Laptop
10. Learner were asked by their Pre-Technical Studies teacher to list property of free hand sketching. Which among the following is **not** a property of free hand sketching?
- A. Erasing and correction
  - B. Transparency
  - C. Texture
  - D. Observation

11. Angela drew a certain symbol on the chalkboard. What does it mean?



- A. Right angle
- B. Diameter
- C. Square
- D. Centre line

12. The following were given as common types of ceramic materials by Grade 9 learners. Which one is **correct**?
- A. Fibre glass
  - B. Concrete
  - C. Porcelain
  - D. Sand papers
13. Identify the note that is **correctly** matched with its theme in Kenyan currency?
- A. Ksh. 50 note - Tourism
  - B. Ksh. 1000 note - Governance
  - C. Ksh. 200 note - Agriculture
  - D. Ksh. 100 note - Social Service
14. Among the following statements, which one does **not** show a form of consumer exploitation?
- A. Standard weight of products
  - B. Poor quality of products
  - C. Overpricing
  - D. Hoarding

15. Grade 9 learners were asked to name the criteria for classifying. Which one is **not** a criteria used in classifying computers?
- A. Size
  - B. Functionality
  - C. Purpose
  - D. Speed

**SECTION B: (35 MARKS)**

**Answer all the questions in the spaces provided.**

16. Grade 8 learners in Nyasore school were discussing on entrepreneurship.

(a). Define the term entrepreneurship (3mks)

---

---

(b). Write down any **three** qualities of a good entrepreneur. (3mks)

(i). \_\_\_\_\_

(ii). \_\_\_\_\_

(iii). \_\_\_\_\_

17. Learners of Grade 9 Simba were having an ICT lessons on the ICT tools used for communication. Identify any **five** tools that they may have identified (5mks)

(i). \_\_\_\_\_

(ii). \_\_\_\_\_

(iii). \_\_\_\_\_

(iv). \_\_\_\_\_

(v). \_\_\_\_\_

18. Fire safety is an important aspect to be adhered to in a workshop.

(a). List down any **three** possible causes of fire in a work place. (3mks)

(i). \_\_\_\_\_

(ii). \_\_\_\_\_

(iii). \_\_\_\_\_

(b). Identify **two** ways of preventing fire outbreaks in a workshop. (2mks)

(i). \_\_\_\_\_

(ii). \_\_\_\_\_

19. (a). Define the term 'Visual programming'.

(2mks)

---

---

(b). List any **three** common examples of visual programming application.

(3mks)

- (i). \_\_\_\_\_  
(ii). \_\_\_\_\_  
(iii). \_\_\_\_\_

20. Learners in Itibo Preparatory were learning on bookkeeping records.

(a). Define the term bookkeeping

(2mks)

---

---

(b). Identify **three** importance of bookkeeping in business.

(3mks)

- (i). \_\_\_\_\_  
(ii). \_\_\_\_\_  
(iii). \_\_\_\_\_

21. Identify the following cutting tools.

(4mks)

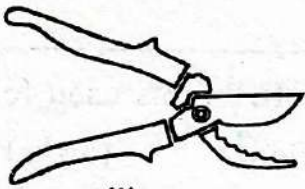

(i)



(ii)



(iii)

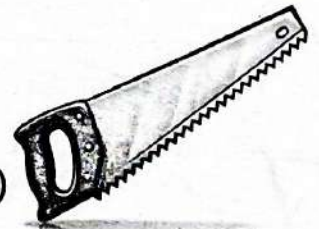

(iv)

- (i). \_\_\_\_\_ (ii). \_\_\_\_\_  
(iii). \_\_\_\_\_ (iv). \_\_\_\_\_

22. Grade 8 learners from Peponi school were discussing on marketing of goods and services.

(a). State **three** sources of information about the possible market for potential customers.

(3mks)

- (i). \_\_\_\_\_  
(ii). \_\_\_\_\_  
(iii). \_\_\_\_\_

(b). List **three** roles of intermediaries in the distribution of goods and services.

(3mks)

- (i). \_\_\_\_\_  
(ii). \_\_\_\_\_  
(iii). \_\_\_\_\_

# KENYA JUNIOR SCHOOL EDUCATION ASSESSMENT

## GRADE 9 - YEAR 2026

### INTEGRATED SCIENCE



001

Name \_\_\_\_\_

Assessment No. \_\_\_\_\_

School \_\_\_\_\_

Date \_\_\_\_\_

Instructions: This paper consists of two sections A and B

TIME: 1HR. 40MIN

#### SECTION A: (15 MARKS)

1. A Grade 9 learner differentiated between an element and a compound. Which of the following is a compound?  
A. Iron                      B. Copper  
C. Carbon dioxide      D. Sulphur
2. During a lesson on separation of mixtures Grade 9 learners separated colour pigments. Identify the method of separation used.  
A. Filtration  
B. Chromatography  
C. Distillation  
D. Decantation
3. During a lesson on application of metals, learners come across Brass, mention how they will classify the mentioned metal.  
A. Compound              B. Elements  
C. Mixture alloy          D. Heterogeneous
4. Grade 8 learners discussed the difference between physical and chemical changes. A compound can be broken down into simpler substances by  
A. physical means  
B. chemicals means  
C. filtration  
D. evaporation
5. Learners were controlling fire which was burning a bush. Which one of the following actions could **not** control the fire?  
A. Turning on the fire alarm.  
B. Cutting off oxygen supply.  
C. Cutting off the source of heat.  
D. Moving fuels away from the fire.

6. During a discussion, learners classified metals and non-metals. Distinguish non-metals only from the ones below.  
A. Sulphur and potassium  
B. Sodium and potassium  
C. Sulphur and chlorine  
D. Helium and calcium
7. The diagram below represents the human digestive system

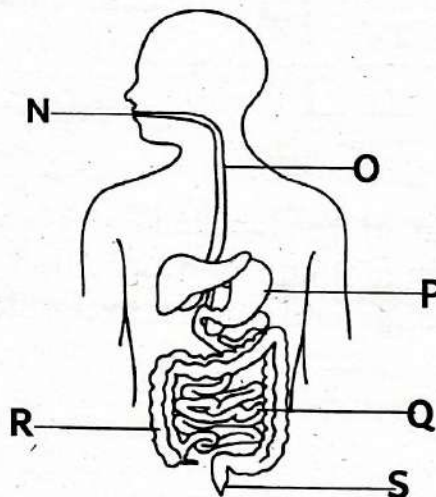

- Which part labelled is primarily responsible for the absorption of digested nutrients into the bloodstream?
- A. P                      B. Q  
C. R                      D. S
8. Learners in Grade 8 observed organisms in their school environment, including a mushroom, a fern, a mosquito and a rose plant. They were asked to classify one that is a fungi. Identify the **correct** answer they gave.  
A. Fern  
B. Mosquito  
C. Mushroom  
D. Rose plant

9. The local community is experiencing increased respiratory problems and acid rain due to emissions from a new factory that burns fossil fuels. Which of the following pollutants is the **most** likely cause of acid rain?
- Carbon monoxide
  - Methane gas
  - Chlorofluorocarbon (CFCS)
  - Sulphur dioxide and nitrogen oxides
10. The diagram below shows a generalised plant cell

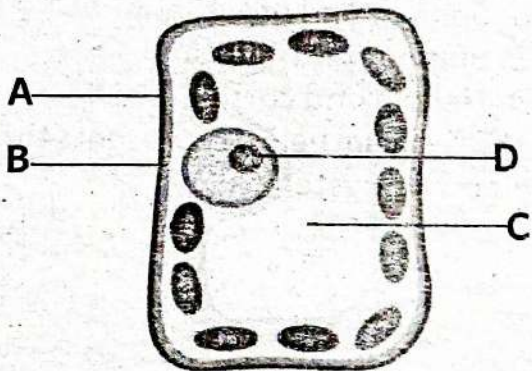

Which of the labelled parts is absent in an animal cell and provided a rigid structure and support to the plant cell?

- B
  - C
  - D
  - A
11. Linet hangs a magnet and notices it aligns itself in a specific North-South direction. This alignment happens consistently regardless of where he hangs it in the room. Which statements **best** explains this phenomenon?
- The force of gravity pulls the magnet towards the Earth's centre
  - The magnet is interacting with the earth's natural magnetic field.
  - Air pressure in the room forces the magnet to orient itself in that direction
  - The temperature of the room affects the magnets polarity causing alignment

12. During an Integrated Science experiment, Grade 8 learners put three droplets of blue ink into a beaker of cold water and another three droplets into a beaker of hot water. They observed that the ink spread faster in the hot water than in the cold water. Which Scientific process were they observing and why did it occur faster in hot water?
- Osmosis** - The higher temperature caused the water molecules to move from a region of low concentration to high concentration.
  - Evaporation** - The heat caused the ink molecules to change state into a gas more quickly.
  - Diffusion** - The heat increased the kinetic energy of both water and ink particles causing them to move and mix faster.
  - Melting** - The heat changed the physical state of the ink allowing it to dissolve.
13. Onyango needs an energy source to power a new irrigation pump of his farm that is both renewable and environmental friendly. Which energy source would **best** fit his requirements?
- Burning diesel fuel in a generator
  - Using a solar powered water pump
  - Using a pump powered by a coal-fired power
  - Burning wood fuel collected from a nearby forest.
14. Photosynthesis is the process by which green plants makes their own food. The main gas released during this process is known as
- |                   |            |
|-------------------|------------|
| A. carbon dioxide | B. oxygen  |
| C. nitrogen       | D. methane |
15. Workers in the steel industry carry heavy loads of steel. Which simple machine can they use to make their work easier?
- A pulley
  - Inclined plane
  - Lever
  - Screw

**Section B : (35 MARKS)**

**Answer all the questions in the spaces provided.**

16. (a). Sodium (Na) is a highly reactive metal, while sulfur(s) is a non-metal that forms rings.

(i). State one characteristic chemical property of non-metals. (1mk)

(ii). When carbon reacts with oxygen it forms carbon dioxide, write a word equation for this reaction. (1mk)

(b). Describe one common use of the element chlorine (Cl) (1mk)

(c). Explain the difference between a mixture and a compound. (2mks)

17. Below is an apparatus used in the laboratory.

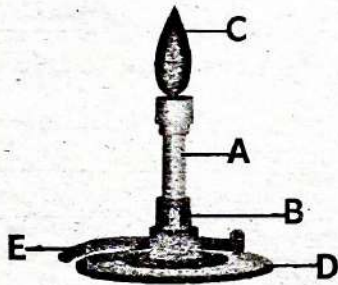

Name the parts labelled A B C D and E respectively. (5mks)

- A \_\_\_\_\_
- B \_\_\_\_\_
- C \_\_\_\_\_
- D \_\_\_\_\_
- E \_\_\_\_\_

18. A patient experiences swelling in their ankles and feet, and their doctor suspects a problem with their kidneys.

(a). Name the main excretory product filtered by the kidneys from the blood. (2mks)

(b). Besides swelling, state **three** other symptoms of kidney disorders. (3mks)

- (i). \_\_\_\_\_
- (ii). \_\_\_\_\_
- (iii). \_\_\_\_\_

19. A child is playing with toy cars that have small magnets embedded in their wheels. (a). Name **three** materials that are strongly attracted by a magnet. (3mks)

(i). \_\_\_\_\_

(ii). \_\_\_\_\_

(iii). \_\_\_\_\_

(b). State **two** common properties of magnets. (2mks)

(i). \_\_\_\_\_

(ii). \_\_\_\_\_

20. A gardener notices that water moves from the soil into the roots of a plant. This process is primarily driven by:

(a). What is the term for the movement of water across a semi-permeable membrane from a region of higher water concentration to a region of lower water concentration? (2mks)

\_\_\_\_\_

(b). Describe the role of the cell wall in a plant cell during this process. (3mks)

\_\_\_\_\_

21. (a). A learner found an unknown clear liquid on the laboratory. They noticed it felt soapy to touch and turned red litmus paper blue. State the general physical properties of this unknown liquid. (2mks)

\_\_\_\_\_

(b). Describe how you would prepare a plant extract from red cabbage to use as an acid-base indicator. (3mks)

\_\_\_\_\_

22. Study the diagram below

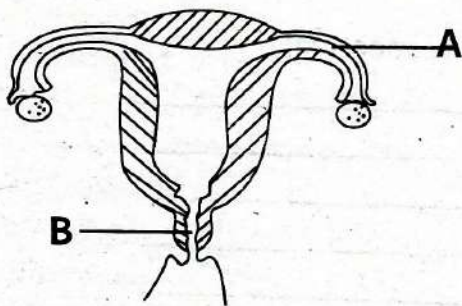

(a). Name the female parts marked A and B. (2mks)

A \_\_\_\_\_

B \_\_\_\_\_

(b). List **three** emotional or social challenges that adolescents might face during puberty? (3mks)

(i). \_\_\_\_\_

(ii). \_\_\_\_\_

(iii). \_\_\_\_\_



001

## MATHEMATICS

## Section A

- 1.D            11.D  
2.C            12.C  
3.B            13.B  
4.B            14.A  
5.C            15.C  
6.A            16.B  
7.B            17.C  
8.C            18.D  
9.D            19.A  
10.C          20.B

## Section B

21.  $2(3x+2y=19)$   
 $3(2x-y=1)$

$$\begin{aligned} 6x + 4y &= 38 \\ -6x - 3y &= 3 \\ \hline 7y &= 35 \end{aligned}$$

$$\frac{7y}{7} = \frac{35}{7}$$

$$y = 5$$

$$\begin{aligned} 2x - 5 &= 1 \\ 2x &= 1+5 \\ \hline 2x &= 6 \\ \frac{2x}{2} &= \frac{6}{2} \\ x &= 3 \end{aligned}$$

22.  $(2^3 \times a^9 \times b^6)^{\frac{1}{3}}$

$$2^{3 \times \frac{1}{3}} \times a^{9 \times \frac{1}{3}} \times b^{6 \times \frac{1}{3}}$$

$$2^1 \times a^3 \times b^2$$

$$2a^3b^2$$

23. 1:10000  
1cm rep 10000cm  
1cm rep 100m  
L=12cm ?  
W = 5cm

$$\begin{aligned} A &= L \times W \\ 1200m \times 500m \\ A &= 600\,000m^2 \end{aligned}$$

$$\left( \frac{600\,000m^2}{10000m^2} \right) ha$$

$$= 60 ha$$

24. ~~BODMAS~~

$$\frac{1}{2} + \frac{9}{10} + \frac{18}{5} - \left( \frac{1}{5} \text{ of } \frac{1}{4} \right)$$

$$\left( \frac{1}{5} \times \frac{1}{4} \right) = \frac{1}{20}$$

$$= \frac{1}{2} + \left( \frac{9}{10} + \frac{18}{5} \right) - \frac{1}{20}$$

$$\frac{1}{2} + \frac{1}{4} - \frac{1}{20}$$

$$\frac{10+5-1}{20}$$

$$= \frac{15-1}{20} = \frac{14}{20}$$

$$= \frac{7}{10}$$

25.  $a=b+1$        $b=4$   
 $4+1$            $c=b-1$   
 $a=5$            $4-1$   
                     $c=3$

$$a=5, b=4, c=3$$

$$\frac{\sqrt{4} \times (3 \times 4 - 3)}{3}$$

$$\frac{2 \times (12 - 3)}{3}$$

$$\frac{2 \times 9}{3} = 6$$

26. (a).  $1 - \left( \frac{1}{4} + \frac{1}{3} \right)$

$$1 - \left( \frac{3+4}{12} \right)$$

$$1 - \frac{7}{12}$$

$$\frac{12}{12} - \frac{7}{12} = \frac{5}{12}$$

$$= \frac{5}{12}$$

(b). Save =  $\frac{5}{12} \times \frac{5000}{60000}$

$$= \text{Sh. } 25000$$

Rent =  $\frac{1}{3} \times \frac{20000}{60000}$

$$= \text{Sh. } 20000$$

$$25000 - 20000 = 5000$$

$$= \text{Sh. } 5000$$

27. John : Tom : Makori  
2 : 3 : 5

$$\begin{array}{ccc} \downarrow & \downarrow & \downarrow \\ \frac{2}{10} & \frac{3}{10} & \frac{5}{10} \end{array}$$

$$\frac{20}{100} \times 1200\,000$$

$$= 240,000$$

$$1,200,000$$

$$- 240,000$$

$$960,000$$

John -  $\frac{2}{10} \times 960\,000$

$$= \text{Sh. } 192\,000$$

Tom -  $\frac{3}{10} \times 960\,000$

$$= \text{Sh. } 288\,000$$

Makori -  $\frac{5}{10} \times 960\,000$

$$= \text{Sh. } 480\,000$$

28. Let x be 0.45

$$x=0.455 \dots i$$

$$10x = 4.555 \dots ii$$

$$100x = 45.555 \dots iii$$

$$100x = 45.555$$

$$- 10x = 4.555$$

$$90x = 41.000$$

$$\frac{90x}{90} = \frac{41}{90}$$

$$x = \frac{41}{90}$$

29.  $\frac{1}{2}(a+b)h = \text{Area}$

$\frac{1}{2}(a+8)12 = 198$

$(a+8)6 = 198$

$6a + 48 = 198$

$6a = 198 - 48$

$6a = 150$

$a = 25$

$NP = 25\text{cm}$

$RP = NP - NR$

$= 25 - 7$

$RP = 18\text{cm}$

30.  $\sqrt{17^2 - 8^2}$   
 $289 - 64 = 225$

$h = \sqrt{225} = 15\text{m}$

T.S.A =  $(Bxh) + (a+b+c)L$   
 $(8\text{m} \times 15\text{m}) + (8+15+17)20$   
 $120\text{m}^2 + (40)20$   
 $120\text{m}^2 + 800\text{m}^2$   
 $= 920\text{m}^2$

31. 3 7 6 8 5 3 2

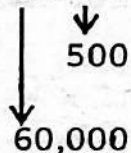

$60\,000 + 500$   
 $60\,500$

32. Check diagram

33. (a).  $9.85 \times 10^{-6}$   
 (b).  $1.50678 \times 10^5$   
 (c).  $2.7432 \times 10^7$   
 (d).  $3.6857 \times 10^1$

34.  $6x + 7y + 3x - 2y$   
 $6x + 3x + 7y - 2y$   
 $= 9x + 5y$

35.  $V = \pi r^2 h$

10

$\frac{22}{7} \times 70\text{cm} \times 70\text{cm} \times 300\text{cm}$

$220 \times 70 \times 300\text{cm}^3$   
 $v = 4620\,000\text{cm}^3$   
 $= 4620 \text{ Litres}$

36. (a).  $C = 2\pi r$  or  $\pi d$

$2 \times \frac{22}{7} \times 8\text{cm}$

$44 \times 8$   
 $C = 352\text{cm}$

(b). 1 Rev = 352cm  
 1000 Rev = ?

$\left( \frac{1000 \times 352\text{cm}}{100\text{cm}} \right)$

$= 3520\text{m}$

ENG PAPER 1

- |      |      |      |      |      |
|------|------|------|------|------|
| 1.A  | 11.B | 21.A | 31.D | 41.B |
| 2.D  | 12.D | 22.D | 32.A | 42.D |
| 3.B  | 13.A | 23.B | 33.B | 43.A |
| 4.C  | 14.B | 24.C | 34.C | 44.C |
| 5.A  | 15.C | 25.A | 35.D | 45.B |
| 6.D  | 16.D | 26.D | 36.A | 46.D |
| 7.C  | 17.A | 27.C | 37.B | 47.C |
| 8.D  | 18.B | 28.B | 38.D | 48.  |
| 9.C  | 19.C | 29.A | 39.A | 49.A |
| 10.A | 20.D | 30.C | 40.C | 50.B |

ENG Paper 2

2. (a). Once upon a time,.....  
 (b). (i). Use of dialogue  
 (ii). Demonstrating (use actions)  
 (iii). Use of suspense - voice projection.  
 (iv). Questioning the audience  
 (vi). Maintain eye contact.  
 (c). (i). hardworking, kind, sympathetic  
 (ii). Generous, provoking, considerate, wise.  
 (d). To try and show the woodcutter the way down the hill.  
 (e). We should return kindness with kindness (Any other relevant lesson)
3. (a). Ten (10)  
 (b). Nurture/future  
 - Game/shame  
 - Flattering/frightening  
 - Use/abuse

4. (a). A health facility  
 (b). Outbreak of cold  
**Poor living conditions - poverty**

- (c). Old man, Mariko  
 (d). **Ignorant - coughing carelessly**  
**Civilised - reading a newspaper**  
**Contented - smiles broadly despite his illness**

5. (a). An estate  
 (b). Kiyingu/Willy/Omido/I  
 (c). To be able to see the passing cars and houses on Block A and B  
 (d). Piled up garbage - Bottles, cans, peelings of potatoes and bananas, car tyres.

Kiswahili Karatasi 1

- |      |      |      |      |      |
|------|------|------|------|------|
| 1.C  | 11.C | 21.B | 31.B | 41.A |
| 2.B  | 12.B | 22.C | 32.A | 42.C |
| 3.A  | 13.B | 23.C | 33.D | 43.B |
| 4.A  | 14.A | 24.B | 34.C | 44.D |
| 5.B  | 15.C | 25.D | 35.B | 45.C |
| 6.C  | 16.D | 26.D | 36.A | 46.A |
| 7.D  | 17.D | 27.B | 37.C | 47.A |
| 8.A  | 18.B | 28.C | 38.B | 48.B |
| 9.A  | 19.C | 29.C | 39.C | 49.B |
| 10.A | 20.C | 30.A | 40.D | 50.C |

KARATASI YA 2

ZOEZI (II) FASIHI SIMULIZI

- (a). Ni hali ya kutokuwa na vurugu au hatari kwa mtu au jamii.  
 (b). Maisha yake huathirika vibaya.  
 (c). (i). Hujitenga na shughuli wanazoshiriki.  
 (ii). Hukosa kujiamini na kujieleza ipasavyo.  
 (iii). Hugeuka bubu .  
 (d). -Kanda magari.  
 -Kucheza karibu na barabara au viziwa vya maji.  
 -Michezo hatari.

- (e). Kujitafutia shida.  
 (f). Kila mmoja

3. ZOEZI (III) NOVELLA

- (a). Tashhisi, semi  
 (b). Nyumbani  
 (c). Mcha Mungu

ZOEZI IV USHAIRI

- (a). Tarbia (b). Tatu  
 (c). Kibwagizo/Mkarara  
 (d). \_\_\_li, \_\_\_ri,  
 \_\_\_li, \_\_\_ri  
 \_\_\_li, \_\_\_ri  
 \_\_\_li, \_\_\_ri  
 (e). Kumi na sita.

**SOCIAL STUDIES**

1. B
2. D
3. A
4. C
5. B
6. D
7. A
8. C
9. B
10. D
11. A
12. C
13. D
14. B
15. A
16. C
17. D
18. B
19. A
20. B
21. (a). linear settlement  
(b). South West  
(c). Fishing  
Mining  
Trade  
Lumbering  
Transport  
(d). Governor  
(e). Christianity  
(f). Cool and wet
22. - Social Sciences  
- STEM  
- Sports
23. Convection currents  
Plate tectonics  
Volcanic activity  
Human activities
24. (i). Critical thinking  
(ii). Social justice  
(iii). Problem -solving
25. (a). Personal skills are essentials abilities for achieving personal and professional goals include resilience communication etc.  
(b). Set boundaries  
Focus on your strength  
Know your values
26. (i). Contour lines  
(ii). Hachures  
(iii). Layer tinting
27. A resource is anything that can be used to make wealth, to satisfy a need or want.  
(b). Water, Minerals, Forest

**INTEGRATED SCIENCE**

1. C
1. B
2. C
3. B
4. D
5. C
6. C
7. B
8. C
9. A
10. C

11. A
12. C
13. B
14. B
15. A
16. (i). Have high electronegativity. They often gain electrons to form negative ions.  
(ii). Carbon + Oxygen - Carbon dioxide.  
(b). Water disinfection.  
(c). A mixture is a combination of two or more substances not chemically combined while a compound is a substance formed when two or more elements chemically combine.
17. A- Chimney  
B - Collar  
C - Flame  
D - Air hole  
E - Gas valve
18. (a). Urea  
(b). Fatigue and weakness  
Nausea and vomiting  
Back or side pain  
Changes in urine
19. (a). Steel, Iron, Tin  
(b). Attract certain materials  
Have two poles
20. (i). Osmosis  
(ii). Fully permeable to water gases and other solutes it allows water and gases to pass through.
21. (a). Bitter taste  
can be caustic  
PH greater than 7  
(b). Chop the red cabbage  
Extract the pigment  
Heat  
Cool  
Filter
22. (a). A- Oviduct  
B - Vagina  
(b). Mood swings  
Self-esteem issues  
Stress and anxiety  
Peer pressure

**AGRICULTURE**

1. B
2. D
3. B
4. C
5. D
6. A
7. B
8. C
9. D
10. C
11. C
12. B
13. B
14. C
15. C
16. (a). Selective removal of certain elements/plants to provide adequate space.

- (b). Better growth and development.  
Improved air circulation.  
Higher yield and quality  
Efficient use of resources.  
Ease of crop management.
17. Age  
Occasion  
Gender  
Nutritional needs  
Budget
- (b). (a). Buffet service - people serve themselves choosing from a variety.  
(b). Family style - Dishes are passed around.
18. Prevents spoilage  
Extends shelf life  
Maintains nutritional value  
Ensures food security.
19. Weather forecasting.  
Market information.  
Agricultural advisory services  
Training services.  
Veterinary services.  
Banking services.
20. Contamination and hygiene issues.  
Freezing in cold weather.  
Inconsistent water supply.  
Overflows and spillage  
High maintenance requirements  
Cost of installation
21. (a). Is the water flowing or the ground after heavy downpour.  
(b). Irrigation  
Washing farm tools  
Watering animals
22. (a). Mopping - Use of a wet to wash a surface.  
Dusting - Wiping or brushing surface to remove dust, dirt.

**PRE-TECHNICAL STUDIES**

1. B
2. A
3. D
4. C
5. B
6. B
7. D
8. D
9. B
10. B
11. D
12. C
13. B
14. A
15. C
16. (a). Is the process of identifying a variable business opportunity awaiting resources to start it and be able to run it.  
(b). Risk taker  
Sole decision maker  
Resilient

17. **Emails**  
 Mobile phones  
 Text messages  
 Video conferencing  
 Social Media platforms  
 Voice communication tools
18. (a). Faulty equipments  
 Keeping flammable materials away from fire.  
 Tidyness
19. (a). A programming when instructions are represented as visual elements.  
 (b). Scratch  
 Blockly  
 Node - Rod
20. (i). Scateur  
 (ii). Scrapper  
 (iii). Chisel  
 (iv). Hacksaw
21. (a). Trade shows and exhibitions  
 Online/Digital market  
 Referrals  
 Trends and innovations  
 (b). Break bulk  
 Reduce transaction costs  
 Customer service and support  
 Market coverage and access

**CREATIVE ARTS AND SPORTS**

- 1.B  
 2.C  
 3.B  
 4.C  
 5.D  
 6.A  
 7.A  
 8.B  
 9.C  
 10.C  
 11.D  
 12.C  
 13.C  
 14.A  
 15.A  
 16.A  
 17.B  
 18.C  
 19.B  
 20.B  
 21. Character  
 Theme  
 Setting  
 22. Running, Dancing, Cycling  
 Swimming, Rope jumping  
 23. Check diagram  
 24. Using the left-hand thumb finger close the back hole.  
 The left-hand index finger closes the first hole.  
 The left-hand middle finger covers the second hole.  
 The ring finger of the left hand covers the third hole.  
 Blow gently into the mouth piece.  
 25. Varied answer. Mark relevant

26. Fosters social cohesion.  
 Promotes identity.  
 Platform for cultural preservation  
 Promotes good health.  
 Promotes citizenship.  
 Promotes patriotism.  
 A source of entertainment.
27. Event: high jump  
 Technique: scissor technique
28. Alliteration  
 Rhyme  
 Repetition  
 Optional section. Answer either question 29 or 30
29. a.  
 Flutter kicks  
 Frog kicks  
 Eggbeater kicks  
 b. Do not swim when sick  
 Do not urinate or defecate in swimming pool  
 Shower/ bath before swimming  
 Do not eat in the swimming pool  
 \*mark any other relevant responses
30. These are activities whereby players chase and attempt to touch each other when running.  
 b. Varied answers: mark relevant. Sample:  
 Mamba game - Giriama community

**CHRISTIAN RELIGIOUS EDUCATION**

1. C  
 2.D  
 3.B  
 4.C  
 5.D  
 6.B  
 7.B  
 8.A  
 9.D  
 10.B  
 11. Humility  
 Faith and trust in a higher vision  
 Perseverance in the face of adversity  
 Courage to confront injustice  
 Servant leadership  
 12. Lack of comprehensive sex education.  
 Peer pressure and social influence  
 Poverty and economic inequality.  
 Sexual abuse and exploitation.  
 Poverty.  
 13. Rape, Incest, Sexual assault  
 14. Obeying Gods call to leave His homeland.  
 Believing Gods promise of descendants.  
 Accepting the covenant and the sign of circumcision.  
 Trusting God for the Birth of Isaac

- Offering Isaac as a sacrifice.  
 Trusting God's justice.
15. Poor communication.  
 Financial problems.  
 Parenting styles and discipline.  
 Generational difference.  
 Lack of time together.  
 Substance abuse or addictions
16. Obedience to God is better than sacrifice  
 Pride leads to downfall  
 Fear of people can lead to sin  
 Jealousy destroys relationship  
 Repentance must be genuine
17. Children  
 Elderly people  
 Disabled
18. Communication with God.  
 Strengthens faith.  
 Provides comfort and peace.  
 Expressions of gratitude.  
 Confessions and forgiveness.

**ISLAMIC RELIGIOUS EDUCATION**

- 1.C  
 2.B  
 3.C  
 4.B  
 5.B  
 6.C  
 7.C  
 8.B  
 9.B  
 10.C  
 11. To fulfil one of the pillar of Islam  
 To seek forgiveness and spiritual renewal.  
 12. Truthfulness (A.S-Sadiq)  
 Trustworthiness (AL-Amin)  
 13. It reduces poverty and helps the needy.  
 It promotes brotherhood among Muslims.  
 14. By performing Wudhu before reading it.  
 By keep it in a clean and high places.  
 15. Obedient to Allah's commands  
 Honest and kind to others.  
 16. Shahadah  
 - Saum  
 - Swalah  
 - Hajj  
 - Zakat  
 17. Muslims should not backbite or slander others.  
 Wealth should not make one proud or arrogant.  
 18. By forgiving those who wrong them.  
 By helping those in need regardless on faith.  
 19. Because it destroys one's faith and is unforgivable sin if not repented.