

Candidate's Name	
School Name	
Candidate's Signature	

Assessment Number	
School Code	
Date	

Time: 2 hours

JUNIOR SCHOOL ASSESSMENT GRADE 9 2025

JESMA 002

- MATHEMATICS -

INSTRUCTIONS TO CANDIDATES

1. Write your **Name** and **Assessment Number** in the spaces provided above.
2. Write the **Name** and **Code** of your school in the spaces provided above.
3. Sign and write the date of the assessment in the spaces provided above.
4. This questions paper consists of **TWO** sections: **A** and **B**.
5. Answer **ALL** the questions in **Section A** on the separate **ANSWER SHEET** provided.
6. Answer **ALL** the questions in **Section B** in the spaces provided in this **QUESTION PAPER**.
7. Show **ALL** your workings in **Section B** in the spaces provided.
8. Non-programmable calculators may be used, except where stated otherwise.
9. Give non-exact numerical answers, correct to 3-significant figures and one decimal places for angles in degrees, unless a different level of accuracy is specified in the questions.
10. For π , use either the calculator value of 3.142
11. **DO NOT** remove any page from this question paper
12. Answer **ALL** the questions in English.

FOR OFFICIAL USE ONLY

SECTION I

Questions	1 - 30
Maximum Score	30
Candidate's Score	
Performance Scale	

SECTION II

Questions	21	22	23	24	25	26	27	28	29	30	31	32	33	34	35	36	37	38	39	40
Maximum Score	4	3	3	3	4	2	5	3	4	4	3	3	2	3	5	5	5	4	3	3
Student's Score																				
Performance Scale																				

GRAND
TOTAL

--

This paper consists of 8 printed pages.

Candidates should check the question paper to ensure that all the pages are printed as indicated and no questions are missing.

SECTION A (20 MARKS)

1. What is 500,400,085 written in words?
 - A. Five hundred million, four hundred and eighty-five.
 - B. Five hundred thousand, four hundred and eighty-five.
 - C. Five hundred million, four hundred thousand and eighty-five.
 - D. Five hundred million, forty thousand and eighty-five.

2. What is the total value of digit 4 in 72.54836?

A. Thousands	B. Hundredths
C. Hundreds	D. Tenths

3. What is the next number in the sequence?
 $2\frac{1}{4}, 2\frac{1}{2}, 2\frac{3}{4}, 3, \text{---}$
 - A. $1\frac{2}{3}$
 - B. $3\frac{1}{4}$
 - C. $3\frac{3}{4}$
 - D. $1\frac{1}{8}$

4. The laboratory technician measured the mass of a substance as 2.628g. Round off the mass of the substance to two decimal places.
 - A. 2.63g
 - B. 2.620g
 - C. 2.630g
 - D. 2.00g

5. Which of the following represents an expression of 12.3258 in three significant figures?
 - A. 12.32
 - B. 12.326
 - C. 12.31
 - D. 12.3

6. A self-help group invested Sh. 4,521,200 in a cooperative society. What is the amount invested in standard form?
 - A. 4.5212×10^{-6}
 - B. 4.5212×10^6
 - C. 4.5212×10^4
 - D. 4.521200×10^4

7. The area of a square roll of fabric is 18.27m^2 . Using a Mathematical table, find the length of one side of the fabric.
 - A. 4.2m
 - B. 4.27m^2
 - C. 4.2742m
 - D. 2.742m

8. Eighteen men working at the same rate can complete a job in 20 days. How many more men working at the same rate can complete the same job in 12 days?
 - A. 12
 - B. 5
 - C. 30
 - D. 6

9. Given that $a=2$, $b=3$ and $y=5$, evaluate .

$$\frac{12a - 3b}{y}$$
 - A. 5
 - B. 15
 - C. 3
 - D. 24

10. Amina had x fruits. She gave out 18 fruits and the ones that remained were less than 9. Write an equation to represent the information.
 - A. $x + 18 > 9$
 - B. $18 - x > 9$
 - C. $x - 9 < 18$
 - D. $x - 18 < 9$

11. Jane had y pencils. The pencils were greater than 4 but less than 9. Which compound inequality below represents the information.

- A. $4 < y < 9$
- B. $9 < y < 4$
- C. $y + 9 > 4$
- D. $4 < y > 9$

12. Kiprono cycled from home to the stadium a distance of 15km. He started the journey at 7.20 am and arrived at 8.00 am. What was his speed in meters per second?

- A. 40 m/s
- B. 6.25 m/s
- C. 2.67 m/s
- D. 7 m/s

13. What is the length of the diameter of a semi-circle whose area is 39.25 cm^2 ?

- A. 25 cm
- B. 6 cm
- C. 10 cm
- D. 5 cm

14. Kevin deposited Sh. 320,000 in a savings account for 2 years. The bank paid simple interest at a rate of 10% per annum. What was the total interest paid by the bank at the end of the 2 years?

- A. Sh. 80,000
- B. Sh. 240,000
- C. Sh. 400,000
- D. Sh. 300,000

15. Mercy bought a washing machine at Sh. 36,400. The value of the washing machine depreciated at a rate of 20% every year. What was the value of the washing machine after two years?

- A. Sh. 18,200
- B. Sh. 29,120
- C. Sh. 23,296
- D. Sh. 32,420

16. Work out the length of the arc MN below.

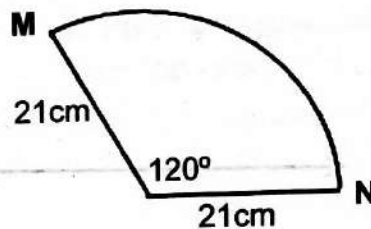

- A. 42 cm
- B. 44 cm
- C. 21 cm
- D. 48 cm

17. What is the surface area of an open cuboid which measures 12m long by 5m wide and 3m high?

- A. 222 cm^2
- B. 240 cm^2
- C. 180 cm^2
- D. 162 cm^2

18. A piece of wood is in the shape of a regular polygon. Each exterior angle is 120° . What is the name of the polygon?

- A. Hexagon
- B. Triangle
- C. Pentagon
- D. Square

19. The scale of a map is 1 cm represents 20m. The actual length of a pavement is 200m. What is the scale length of the pavement?

- A. 20cm
- B. 5cm
- C. 10cm
- D. 15cm

20. The age in years of eleven people, was recorded as follows: 26, 27, 26, 28, 26, 25, 29, 28, 27, 26 and 28. What is the modal age of the people?

- A. 26
- B. 27
- C. 28
- D. 25

SECTION B (80 MARKS)

21. Using a number line, perform the following operations. (4mks)

a) $+8 - 3$



b) $-7 - 3 + 6$



22. Arrange the following fractions in a descending order. (3mks)

$$\frac{2}{5}, \frac{3}{5}, \frac{3}{40}, \frac{7}{20}$$

23. Evaluate: (3mks)

$$5\frac{1}{6} - \frac{1}{12} \times 1\frac{1}{6} + \frac{5}{6}$$

24. The length of a rope is 3.12m.
Convert the length of the rope into a fraction.

(3mks)

25. Grade 9 learners were reviewing the lesson on the squares of decimal numbers using tables.

a) Determine how they wrote the standard form of 0.0321. (2mks)

b) From the square tables, what is the square of 0.0321? (2mks)

26. During the festive season, the bus fare increased by 20%. What would be the new bus fare between two towns whose original fare was Sh. 800? (2 mks)

27. Anyona mixed maize and beans in the ratio 1: 5. Maria mixed maize and beans in the ratio of 2: 3.

a) Which ratio of the mixture was greater than the other? (3 mks)

b) Which mixture had more beans than the other? (2 mks)

28. A farmer shared his harvest among his two children. One child received $\frac{2}{3}$ of the harvest and the other received $\frac{5}{6}$ of the remainder. The farmer remained with 8 bags. How many bags did the farmer have before sharing? (3mks)

29. Wafula is five times as old as his son.

By letting his son's age be y .

a) Write an expression for the sum of their ages. (2mks)

b) Work out the sum of their ages if the son's age is 8 years. (2mks)

30. Use substitution method to solve this pair of equations. (4mks)

$$3x + y = 15$$

$$2x - y = 5$$

31. The cost of five books and 4 geometrical sets is sh.2 300.. Susan bought 2 of the books and 2 of the geometrical sets for sh. 1000. Find the cost of each item. (3mks)

32. A 3m high wall has ladder inclined on it. If the ladder is placed 4m away from the foot of the wall, what is the length of the ladder? (3mks)

33. A cylindrical container has a diameter of 9.1cm. What is the circumference of the top of the container? (2mks)

34. Stephen tethered his sheep using a rope with a length of 7m. Calculate the maximum grazing area of the sheep. (3mks)

35. A cylindrical tank has a diameter of 14.4m and a height of 12m.

a) Calculate the surface area of the closed tank. (3mks)

b) Write your answer from (a) above correct to four significant figures. (2mks)

36. The cash price of a cooker was sh. 60,000. Theuri bought the cooker on hire purchase. He paid a deposit of sh. 15,000 and the balance in 12 months at sh. 4,000 per month.

a) How much did he pay for the cooker? (3mks)

b) How much more than the cash price did he pay? (2mks)

37. Otieno deposited sh. 300,000 in a bank for 2 years. The bank paid compound interest at a rate of 8% per annum.

a) Calculate the interest he earned after the two years. (3mks)

b) How much money did he have at the bank after two years? (2mks).

38. Construct a parallelogram $ABCD$ whereby $AB=5\text{cm}$, $BC=3\text{cm}$ and angle $BAC=20^\circ$.

Measure;

a) The size of angle ABC . (2mks)

b) The length of line BD . (2mks)

39. Construct triangle XYZ such that $XY=3\text{cm}$, $YZ=4\text{cm}$ and $XZ=5\text{cm}$. Construct a circle that passes through the vertices of the triangle. Find the radius of the circle. (3mks)

40. The pie chart below shows the number of bags sold by a business man. The total number of bags in the shop was 540.

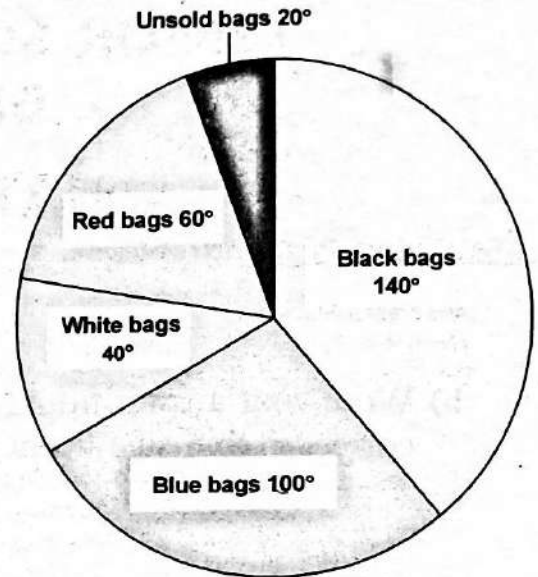

a) How many bags did he sell? (1mk)

b) How many more black bags than blue bags did he sell? (1mk)

c) What is the total number of red bags sold? (1mk)

Candidate's Name	
School Name	
Candidate's Signature	

Assessment Number	
School Code	
Date	

JUNIOR SCHOOL ASSESSMENT GRADE 9 2025

**JESMA
002**

002-2025 - ENGLISH PAPER 1-

KJSEA

901/1

ENGLISH (*Reading comprehension, Oral skills and Grammar*)

Paper 1

Time: 1hr 40 minutes

INSTRUCTIONS TO CANDIDATES

1. You have been given this question paper and a separate answer sheet. The question paper contains 50 multiple choice questions.
2. Answer **ALL** questions on the **ANSWER SHEET** provided, **NOT** on the question paper.
3. Do any necessary rough work in this booklet.
3. When you have chosen your answer, mark it on the **ANSWER SHEET**, not in the question booklet.

HOW TO USE THE ANSWER SHEET

4. Use an ordinary **HB** pencil.
5. Confirm that the answer sheet you have been provided with has the following:

YOUR ASSESSMENT NUMBER

YOUR NAME

NAME OF YOUR SCHOOL

NAME OF THE SUBJECT
6. Keep your answer sheet as clean as possible and do not fold it.
7. For each of the questions 1 – 50, four options are given. The answers are lettered **A, B, C** and **D**. In each case only **ONE** of the four options is correct. Choose the **correct** option.
8. On the answer sheet the correct answer is to be shown by drawing a **DARK LINE** inside the box in which the letter you have chosen is written.

Example

In the Question Booklet:

In question 16, choose the correct word to fill in the blank space.

16. Jean has been absent _____ school for three days.

- A. of
- B. in
- C. from
- D. at

The correct answer is 'C'

On the answer sheet:

In the set of boxes given for number 16, draw a dark line inside the box with the letter C printed in it is marked below.

16 (A) (B) (C) (D)

9. Your **dark line MUST** be within the box. **DO NOT** make any marks outside the boxes.
10. For each question **ONLY ONE** box is to be marked.

This question paper consists of 8 printed pages.

Candidates should check the question paper to ensure that all the pages are printed as indicated and no questions are missing.

Website: www.jesmapublishersltd.com

E-mail: info@jesmapublishersltd.com/jesmapublishers@yahoo.com

002 © Jesma Publishers & Educational Boosters Ltd. Tel: 0701545759/0794677748

TURN OVER

SECTION A: ORAL SKILLS (10MKS)

Task 1: Read the following passage and then answer the questions that follow. (6 mks)

We make friends in life and some of them begin quite early in life. Do you remember any of your friends you made in your Early Year Education or Nursery school? Some of us do but it is not that all of them are still friendly to us as they were that time.

As you grow up some many changes takes place in you. You may realise that you eat alot of late or get attracted to a style of dressing .This will definately affect the friends you will keep. There is no way you will befriend a football fanatic while your main interest is farming for example. Definately you will look for those who enjoy the kind of music, dress up like you, appreciate a few things about you and even share a number of common interests. Do you remember the common proverb that states " Birds of a feather flock together"?

Friends do stand with us when we need them. When you need to borrow something including money a good friend should not ask you too many investigative questions on when you will repay it and why you need it. It should be that they help you or not. If you don't get help from that friend ,its not the end of the world. Probably, they dont have whatever you wanted so move on to the next person. That should not affect your friendship.

1. The question in the first paragraph suggests that
 - A. The friends we have must have been our schoolmates.
 - B. Schools teach people how to make friends.
 - C. Some people start making friends very early in life.
 - D. The first lesson in school usually is on making friends.
2. Why do we lose friends and make others in life?
 - A. Changes that takes place in us makes us change interests.
 - B. The friends tend to lead us the wrong way.
 - C. Our friends gets attracted to better friends.
 - D. Life is too long to retain the same friends.
3. What is the **main** reason that makes people change their friends?
 - A. Family.
 - B. Dressing
 - C. Interests.
 - D. School setup.
4. The proverb 'birds of a feather flock together' means
 - A. Friends must always do things the same way
 - B. You can only befriend those whose interests are like yours
 - C. You should never allow your friends to make other friends
 - D. Your friends must be in your groups all the time.
5. How should our friends treat us when we need assistance from them?
 - A. They should press us to give full information .
 - B. They must first compare us to others.
 - C. They should ask us to try others too.
 - D. They should trust what we tell them.

6. If a friend fails to help you, it could be because
- A. they too lack the capacity to help you.
 - B. you are not really a friend to the person.
 - C. the friendship between the two of you is not genuine
 - D. you have never helped them.

Task 2: Read the following passage and then answer questions 7-11.

The onset of the rain is always taken as a blessing. Just before it starts, the environment looks **bare** and dry. Many trees shed off their leaves and can be mistaken to be dry. On the ground there is hardly any sign of life. Both the grass and shrubs are dry and it becomes difficult to imagine that actually they are still alive but dormant. The animals too, have to adopt to different ways of life. They move from place to place in search of water and food. Some survive while a few are never so lucky.

The moment the first droplet of rain hits the ground, life starts changing. In a few days, seeds of grass start sprouting and as the rain continues, the ground gets covered. That is when the big trees sprout new leaves and within a few days, some plants starts flowering. The rain therefore controls how our environment looks and continuity of life of both animals and plants.

7. Which of the four words below means the same as **bare** as used in paragraph 1
- A. Dead.
 - B. Dry.
 - C. Dusty
 - D. Uncovered
8. During the dry season all the following happens **except**
- A. All plants dry up
 - B. The ground looks bare.
 - C. Some trees drop their leaves.
 - D. The animals find it difficult to survive
9. If animals do not move from place to place,
- A. Rains may not fall
 - A. The ground could remain bare.
 - C. They could die easily.
 - D. More rain falls than expected
10. By saying life starts changing, the writer means that
- A. Plants starts shedding their leaves
 - B. Plants grow and animals get food easily.
 - C. Animals start taking less water.
 - D. More rains fall than expected
11. When some plants start flowering it is a sign that
- A. More seeds are soon being produced
 - B. Rain is soon becoming less
 - C. The animals should not eat them.
 - D. The plants are ready to be consumed by animals

Task 3: Read the following story and then answer the questions that follow.

I was thrilled when the time finally came for me to join junior school. But when I arrived in the school, I realised that it was like stepping into a whole new world. The school had a lot of activities. Everything in the school felt bigger, faster and more intense than primary school. When the announcement for the first monthly assessment came, my stomach churned. "This is it," I thought. "My chance to prove myself."

The week before the test, I buried myself in textbooks and notes. My evenings were spent bent over a desk, the pages blurring as the clock ticked past midnight. By the time assessment day arrived, my brain felt like an overstuffed suitcase, barely able to hold any more information.

As I stared at the Mathematics questions, panic set in. The numbers danced mockingly on the page and my mind drew a complete blank. It was as if someone had erased all my hard work with one swift stroke. By the time the exam ended, my hands trembled and I could barely meet my teacher's eyes as I handed in my paper.

A week later, the results were out. My heart sank as I saw my Mathematics paper covered in red marks like a battlefield. The score was so low, I wished the ground could swallow me alive. My classmates celebrated their successes, but I sat at my desk, trying to blink back tears. "Maybe I'm just not cut out for this," I thought.

But then, something inside me stirred. I felt like giving up I thought of my parents, their sacrifices to ensure I could attend a good school. I thought of my teacher, who believed in me. And most importantly, I thought of my future self, the person I wanted to become. I wiped my tears and whispered to myself, "No more excuses. I can do this."

From that day on, I made a promise. Each evening, I revised every mistake from the test until I understood where I went wrong. If I didn't know an answer, I asked my teacher or a classmate. My desk became my battlefield. When the second monthly assessment came around, I felt nervous but prepared. This time, the numbers didn't mock me; they lined up neatly in my head, waiting for me to solve them. When the results were announced, I held my breath and then exhaled in relief had done it. I had to read the mathematic test!

12. How did the narrator feel about joining junior school?
- A. Excited
 - B. Overworked
 - C. Nervous
 - D. Confident
13. How did the narrator feel during the Mathematics test?
- A. Calm and focused.
 - B. Panicked and blank-minded.
 - C. Confident and determined.
 - D. Excited and happy.
14. What did the narrator see when he received his first Mathematics test results?
- A. A paper covered in red marks.
 - B. Encouraging comments from the teacher.
 - C. A perfect score.
 - D. A blank sheet.
15. What thought motivated the narrator to work harder after the poor results? His
- A. love for Mathematics.
 - B. desire to make friends.
 - C. parents' sacrifices and future goals.
 - D. teacher's disappointment.

16. What strategy did the narrator adopt to improve in Mathematics?
- A. ignored the mistakes. C. focused on other subjects
 B. practised solving different types of puzzles. D. revised his work and asked for help

Read the following passage and then answer the questions that follow.

Four learners, Kuria, Janet, Kimotho, and Fatuma went to a hotel for lunch. Janet ate rice and chicken while Kuria ate beef stew and chapati. Kimotho ate Chapati and beans while Fatuma took pilau and chicken. Kuria and Kimotho took soda while Fatuma took orange juice. Janet had a glass of pineapple juice. All the learners ate a banana except Janet who took pears. Only Fatuma took water

17. Who among the learners took soda, beans, chapati and bananas?
 A. Janet
 B. Fatuma
 C. Kimotho
 D. Kuria
18. The learner who took the **highest** number of items at the hotel is?
 A. Fatuma
 B. Kuria
 C. Janet
 D. Kimotho
19. Which food item taken by Fatuma was also taken by Janet?
 A. Banana
 B. Chicken
 C. Pineapple juice
 D. Pilau
20. The **most** liked fruit among the learners is
 A. Pears
 B. Orange
 C. Pineapple.
 D. Banana

Read the following telephone conversation and then answer the questions that follow.

Simon: Hallo Charity.

Charity: Halo Simon. How are you doing?

Simon: _____ 21 _____

Charity: I found your exercise book for Mathematics among mine

Simon: Thank you. I've been looking for it. _____ 22 _____ I couldn't remember where I had left it.

Charity: _____ 23 _____ When we had a group discussion at your desk.

Simon: That is true. I will come for it in the afternoon.

Charity: Welcome. I'll just be at home in the afternoon.

21. A. I'm very good and you
 B. I'm just relaxing at home
 C. I'm ok and grateful to you
 D. I'm fine thank you.
22. A. I misplaced it yesterday
 B. I know someone has stolen it
 C. I will never see it again
 D. Other people have lost theirs too.

23. A. It is possible to lose your items
 B. Did you ask me for it
 C. I must have taken it by mistake
 D. You can collect it.

For questions 24 and 25, select the alternative that Best describes what you would say in each of the situation presented.

24. Anna is left to take care of the baby. The baby is crawling towards the stair case.
 What would you tell her?
 A. Does the baby know how to use the stairs.
 B. Hey! watch what the baby is doing.
 C. Is that hoe to take care of the baby.
 D. What did I expect from you?.

25. You are standing in the parade ground. Someone steps on your toe. What will you say?
 A. Whose toe do you think you are steping on?
 B. Get your foot off my toe!.
 C. Do you want me to step on yours too.
 D. Excuse me, you are stepping on my toe.

Read the passage below. It contains blank spaces 26-35. For each blank space , choose the best alternative.

We go hospital 26 we fall sick. This is because we need to be treated and recover so that we can continue with our daily 27 . The hospital has different 28 . Some suffer from diseases like malaria, cough and dysentery 29 others could have contracted typhiod. There are also those who have got accidents and need 30 treatment to save their lives. This 31 why we may not get treatment 32 the hospital as fast as we always expect to. The very 33 and accident 34 need to be given priority. Likewise, it is 35 to stop taking your drugs just because you have started feeling some relief.

- | | | | |
|-----------------|--------------|---------------|-------------|
| 26. A. while | B. as | C. whenever | D. since |
| 27. A. routine | B. things | C. lives | D. bread |
| 28. A. people | B. medicines | C. groups | D. patients |
| 29. A. then | B. while | C. also | D. and |
| 30. A. proper | B. real | C. urgent | D. new |
| 31. A. explains | B. states | C. summarises | D. suggests |
| 32. A. in | B. at | C. by | D. on |
| 33. A. strong | B. fast | C. healthy | D. weak |
| 34. A. ones | B. people | C. victims | D. team |
| 35. A. funny | B. wrong | C. great | D. wise |

Task 8: Grammar

For questions 36 and 37, choose the best alternative to complete the sentences.

36. These girls like playing rope skipping, _____?
A. isn't it B. do they
C. don't they D. is it

37. They rarely go out at night, _____?
A. do they B. aren't they
C. don't they D. have they

For questions 38 and 39, choose the word that can be used in the place of the underlined phrase.

38. The meeting was put off until a later date.
A. stopped B. cancelled
C. ended D. postponed.

39. At the party, we ate the flesh of a calf.
A. veal B. bacon
C. venison D. beef

For questions 40 and 41, complete the sentences with best alternative.

40. I did not find my bag where I left it, I think _____ must have taken it.
A. nobody B. anybody
C. somebody D. everybody

41. The son of the late president _____ wreath on his grave.
A. lay B. lain
C. lied D. laid

For questions 42 and 43, complete the sentences with the correct order of adjectives.

42. Nelly bought a _____ dog.
A. lovely small young brown
B. small lovely young brown
C. brown small lovely young
D. young lovely brown small

43. Which sentence uses the correct order of adjectives?
A. The table is round wooden.
B. The table is wooden round.
C. The table is a wooden round.
D. The table is a round wooden

For questions 44 and 45, choose the best word to complete the sentences.

44. The goods that Kenya _____ to other countries earn foreign exchange.
A. imports
B. exports
C. transports
D. buys

45. My mother went to the market to buy _____ such as knives, forks and spoons.
A. vessels
B. crockery
C. cutlery
D. crates

For questions 46 and 47, select the alternative that best completes the sentence

46. Had the ambulance come in time, _____
A. the patient had survived.
B. the patient would survive.
C. the patient would have to survive.
D. the patient would have survived.
47. As soon as the guest-of-honour arrived,
A. the meeting could start
B. the meeting started
C. the meeting would soon start
D. the meeting would have started

For questions 48 and 50 choose the odd one out.

48. A. hold B. touch
C. grab D. catch
49. A. beans B. maize
C. cassava D. rice
50. A. cat B. goat
C. puppy D. sheep

Candidate's Name	
School Name	
Candidate's Signature	

Assessment Number	
School Code	
Date	

JUNIOR SCHOOL ASSESSMENT GRADE 9 2025

**JESMA
002**

- ENGLISH PAPER 2 -

KJSEA

901/2

ENGLISH (*Composition and Literary Analysis*)

Paper 2

Time: 1hr 45 minutes

INSTRUCTIONS TO CANDIDATES

1. Write your **Name** and **Assessment Number** in the spaces provided above.
2. Write the **Name** and **Code** of your school in the spaces provided above.
3. Sign and write the date of the assessment in the spaces provided above.
4. This questions paper consists of **two sections: A and B** questions.
5. Answer **ALL** the questions in this paper.
6. Write **ALL** the answers in the spaces provided in this **QUESTION PAPER**.
7. **DO NOT** remove any page from this question paper
8. Answer **ALL** the questions in English.

FOR OFFICIAL USE ONLY

	SECTION A	SECTION B			
Task	Task 1 Question 1	Task 2 Question 2	Task 3 Question 3	Task 4 Question 4	Task 5 Question 5
Maximum Score					
Candidate's Score					

This paper consists of 8 printed pages.

Candidates should check the question paper to ensure that all the pages are printed as indicated and no questions are missing.

SECTION B: LITERARY ANALYSIS (35MKS)

Answer ALL questions in this section

TASK 2: ORAL LITERATURE

Read the story below and then answer the questions that follow.

(10mks)

THE HARE AND THE HYENA

One morning, Hare was looking for something to eat. He spotted Hyena under a tree. Hyena looked hungry, as usual.

"Good morning, Hyena," Hare called out cheerfully.

"Morning, Hare," grumbled Hyena, licking his chops. "What brings you here?"

"I found a secret feast hidden near the river," Hare said slyly. "But it's too much for me to eat alone. Would you like to join me?"

Hyena's ears perked up. "A feast? Of course, I'd like to join. Lead the way."

Hare walked ahead, leading Hyena through the tall grass. As they walked, Hare spoke. "The feast is in a cave near the riverbank, but there's a catch. The cave belongs to Lion and he guards it fiercely. We'll have to trick him."

Hyena's stomach growled loudly and he nodded eagerly. "Tell me the plan!"

Hare grinned. "You will go into the cave and distract Lion by roaring loudly. While you keep him busy, I'll sneak in, grab the food and run back here. Then we'll share it equally."

Hyena, too greedy to think twice, agreed to the plan. He crept into the cave and began roaring with all his might. His noise woke up the angry Lion.

Meanwhile, Hare was outside, laughing quietly. He had no intention of going near the cave. Instead, he found a nearby patch of grass and enjoyed a meal while Hyena scrambled out of the cave, chased by the furious Lion.

Hyena ran until his legs gave in and he collapsed in a bush, panting. "That sneaky Hare!" he muttered.

From a safe distance, Hare called out, "Next time, Hyena, don't let your greed lead you into trouble!" Hare hopped away, leaving Hyena to learn his lesson the hard way.

1. What did Hare claim to have found near the river? (1mk)

2. What was Hyena's reaction to Hare's offer? (1mk)

3. How would you describe Hare's character according to the story? (1mk)

4. How can you describe the Hyena? (1mk)

5. Explain how the Hare had planned to get the food from the cave. (2mks)

6. What happened to Hyena when he entered the cave to distract Lion? (1mk)

7. Explain the moral lesson we can learn from this story (2mks)

8. What do we call the above narrative? (1mk)

TASK 3: POETRY

3. Read the following poem and then answer the questions that follow. (5mks)

Education is the key

When people look at me,
They see someone not meant to be,
They see I'm different, they see I'm strange,
They think my life will never change.
But I'm proud of who I am,
I'm proud of all I've overcome.
I didn't give up, I didn't fall,
I kept on fighting, I stood tall.

I love my family; I love my land,
I want to help with a giving hand.
I sought my dreams; I made a vow,
And education has shaped me now.
My mother pushed, she didn't rest,
She wanted for me only the best.
When I was young, it felt so tough,
But now I know I'm strong enough.
Without education, I'd feel so small,
But now I stand proud and tall.
Education is my guiding light,
It makes me brave, it makes me bright.
So when they look, let them see,
A strong, educated woman - me!

a) What is the **main** theme of the poem? (1mk)

b) Identify **two** pairs of rhyming words from the poem. (1mk)

- c) Which phrase is repeated in the poem? (1mk)
-
- d) How many stanzas does the poem have? (1mk)
-
- e) Who is the persona in the poem? (1mk)
-

TASK 4: PLAY

4. Below is an excerpt of a play. Read it and then answer the questions that follow. (10mks)

The Lost Pen

Scene 1: The Living Room

(Tina is sitting at the table, doing her homework. Ben enters, looking worried.)

Ben: *(Frantically)* Tina! Have you seen my red pen? I can't find it anywhere!

Tina: *(Looks up)* Your red pen? Hmm, wasn't it on your desk?

Ben: *(Shakes his head)* No, it's not there. I checked under the books and even under the bed!

Tina: *(Smiling)* Don't worry, let's think. When did you last use it?

Ben: *(Scratching his head)* I think... I used it yesterday to draw a rocket. Then I... Oh no! I don't remember!

(Mama enters with a basket of folded clothes.)

Mama: *(Noticing Ben's worried face)* What's the matter, Ben?

Ben: Mama, I lost my red pen! It's my favourite pen and I can't find it.

Mama: *(Calmly)* Have you looked in the living room?

Ben: *(Nodding)* Yes, I even looked under the sofa.

Mama: Hmm, let's try something. Close your eyes and picture yourself drawing the rocket. What did you do after that?

Ben: *(Closing his eyes)* I remember drawing the rocket... then I went to the kitchen to get a snack. Oh! Could I have left it on the counter?

Tina: *(Clapping)* That's it, Ben! Let's go check the kitchen.

Scene 2: The Kitchen

(The three walk into the kitchen. Ben spots the red pen on the counter.)

Ben: *(Excitedly)* There it is! My red pen! Thank you, Mama, and thank you, Tina!

Mama: *(Smiling)* See, thinking calmly helps. Next time, try to put your things back where they belong.

Tina: *(Teasing)* Or hire me as your official pen detective.

Ben: *(Laughing)* Deal!

(They all laugh and walk back to the living room together.)

- a) Where does the first scene of the play take place? (1mk)
-

- b) How many scenes are in the play? (1mk)

- c) Describe how Ben eventually remembered where he left the pen. (2mks)

- d) What lesson does Mama teach Ben about keeping his things organised? (2mks)

- e) How would you describe Ben's character at the beginning of the play? (2mks)

- f) What trait does Tina show when she helps Ben find his pen? (1mk)

- g) What happens at the end of the play? (1mk)

TASK 5: NOVELLA

Below is an excerpt of a Novella. Read it and then answer the questions that follow.

When Peter entered the headmaster's office, he did not know what to expect.

The look on the headmaster's face told him all was not well.

"Ah, Peter. So you are letting things slip after only six months."

"No, Sir." "Are you calling the teacher a liar?"

"No, Sir."

"Are you tired of working hard? Letting me down? None of the others have, you know. Do you want to do only the ordinary classes?"

"No, Sir."

"You'd better tell me all about it"

"It's Arithmetic, Sir."

"What about it?"

"I can't do it, Sir."

"Have you tried?"

Yes, Sir."

"Hard?"

"Yes, Sir."

"This record says you show no interest in it."

"I've tried, Sir."

"Oh, you mean the record is untrue?"

"No, Sir. I mean I've tried hard to be interested."

"And failed."

"Yes, Sir."

"You know, of course, that I don't make laws about examinations."

"Yes, Sir."

“Well, unless you get a certain average in Arithmetic, your very high average in all the other subjects won't help you. That is the law and I didn't make it. I want to push you through as fast as I can, but you must work at Arithmetic. Relax a little with the other subjects, if you like.”

“I like the other subjects, Sir.”

“I know. But to get where you want to go, you can't do what you like. Where do you want to go? What do you want to do?”

“Those stories, Sir.” “In the book the young woman gave you?”

“Yes, Sir.” “I was beginning to wonder whether you had begun to forget them.”

“I'm trying to read them now, Sir.”

“Getting anything out of it?”

“A little.”

“Well, there you have it. Between you and the further knowledge that would help you to get everything out of that book stands Arithmetic. It's like a lion barring your road. You either turn back because you cannot cope with it, or you kill it and go on. There is no other way. Arithmetic is silly in a poet's armoury, but you must master it and get that average I promised you my cane if you were ever sent to me. We must keep our promises. Let down your trousers, then go back and let the sting of the cane help you to kill the lion.”

- a) What subject was Peter struggling with? (1mk)

- b) Where is the conversation between Peter and the head master taking place? (1mk)

- c) What did the headmaster compare Arithmetic to? (1mk)

- d) What was the reason the headmaster said Peter must pass Arithmetic? (1mk)

- e) Why do you think Peter was struggling to show interest in Arithmetic despite trying? (2mks)

- f) Do you think the headmaster's comparison of Arithmetic to a lion was appropriate? Why or why not? (2mks)

- g) Describe the character of the headmaster from the way he speaks to Peter? (1mk)

- h) What moral lesson can we learn from Peter's experience? (1mk)

Jina la Mtahiniwa		Nambari ya Mtahiniwa	
Jina la Shule Yako		Nambari ya Shule	
Sahihi ya Mtahiniwa		Tarehe	

Muda: Saa 1 Dakika 45



TATHMINI YA SHULE YA JUNIA GREDI 9 2025

**JESMA
002**

- KISWAHILI KARATASI YA 2-

**KJSEA
901/2
KISWAHILI LUGHA
Karatasi ya 2
Muda: Saa 1 dakika 45**

MAAGIZO WA WATAHINIWA

1. Andika jina lako na nambari yako ya mtihani kwenye nafsi uliyoachiwa hapo juu.
2. Andika jina na nambari ya shule yako kwenye nafasi uliyoachiwa hapo juu.
3. Tia sahihi kwenye nafasi uliyoachiwa hapo juu.
4. Andika tarehe ya mtihani ipasavyo.
5. Jibu maswali yote.
6. Andika majibu yote kwa nafasi ulizoachiwa katika kijitabu hiki.
7. Majibu yote ni lazima yaandikwe kwa lugha ya Kiswahili.

MATUMIZI YA MTAHINI PEKEE

	SEHEMU A	SEHEMU B			
	Zoezi 1 Insha	Zoezi 2 Fasihi Simulizi	Zoezi 3 Novella	Zoezi 4 Tamthilia	Zoezi 5 Ushairi
Alama ya upeo	15	10	10	10	5
Alama ya mtahiniwa					

Kijitabu hiki kina kurasa 8 zilizopigwa chapa.

Watahiniwa ni lazima wahakikishe kwamba kurasa zote za karatasi hii zimepigwa chapa sawasawa na kuwa maswali yote yamo.

SEHEMU B: (Alama 35)

(Alama 10)

ZOEZI 2: FASIHI SIMULIZI

(al 2)

a) Eleza tofauti kuu baina ya hurafa na hekaya

b) Taja umuhimu wa hurafa na hekaya katika jamii.

(al 2)

c) Taja vipengee vya kuzingatia wakati wa kuwasilisha hurafa au hekaya

(al 5)

i)

ii)

iii)

iv)

v)

d) Taja mbinu za lugha zilizotumiwa katika kazi hii.

(al 1)

ZOEZI 3: NOVELLA (Alama 10)

Mwanahabari alifungua kinywa kutaka kuuliza lakini kabla ya swali lake, mzee alikuwa tayari na jibu; "najua mngenda kupata majibu ya maneno yangu. Sijui ikiwa mzigo nitautua salama. Mungu amenipa mzigo wa kuhakikisha kijana anapewa mawaidha ya kumfanya kuwa mtu, akubali kuishi na watu na akubali kuwachukua watu. Sijui ikiwa dunia itamkubali kuwa naye pia ni mtu kwani dunia ilivyo hadaa na walimwengu wake mashujaa imejaa viatu, kutu na akali ya utu. Hata hivyo, namwachia mwenyezi Mungu alivyoyaanzisha na awe tayari kuyakamilisha. Namtaka kila mmoja atakayekutana na kutagusana na Jasiri ajitahidi kumvumilia na kumwonyesha siri ya ujasiri. Asanteni kwa kuja." Alisimama na kukichukua kiserema kurejea mgundani.

Wakati ule, vijana wanne walifika na mapipa ya plastiki manne wakayabwaga chini na kumwagalia Jasiri ili kupata maelekezo zaidi. Wanahabari walimhoji Jasiri kuhusu mradi wake wa maji naye akawajibu barabara kiasi cha kuwafanya kumwita mhandisi kweli. Walimaka alivyotongoa hoja zake. "Mnaona pale mlimani? Kuna maji yanatiririka kwenye kijito fulani kwa jina Kulamka. Nimewahamasisha vijana wenzangu tukakubaliana kujenga ulingo wa kuyaweka haya mapipa machakavu ya plastiki. Tutaunga mabomba ya plastiki ili maji yajae kwenye mapipa haya. Baba yangu ameongea na wenzake wachache wakatupatia ahadi ya miti ya kutumia kama milingoti ya kusambazia mifereji ya maji katika mashamba haya mnayoyaona yamelimwa."

"Mifereji tutakayoninginiza mashambani tutaitoboa ili maji yanyunyizike mashambani na kuulovya udongo kwa upanzi. Kazi ya kujaza maji tutaifanya kwa zamu sisi wenyewe. Tunapanga

kupanda aina nyingi za mboga na kuziua. Faida kama itakuwapo tuna mpango wa kufuga kuku wa mayai na wa nyama. Hii ni kazi itakayotupa riziki na kukiwezesha kijiji hiki kujiinua kiuchumi. Tunataraji kupata marafiki na wasamaria wa kutusaidia kwa vifaa mbalimbali ili kutimiza ndoto yetu. Asanteni kwa kupeleka habari hizi nje. Mungu awabariki.”

Jasiri aliwaalika vijana wenzake kijijini wakakaa na kukubaliana jinsi watakavyofanya kazi ya kusambaza maji shambani. Walipofika mkutanoni, Jasiri alijikohoza na kusema; “Jumamosi tufike saa tatu. Tutapandisha yale matangi manne kwenye ile miamba pale kisha tuchukue tanki lile dogo tuliweke pale kwenye ule mwamba. Tutachukua mabomba manne tutoboe tuyaingize kwenye tanki hilo dogo ili maji yatakayoingia humo tankini yatiririke hadi kwenye matanki yale makubwa manne. Hili linaweza kuchukua siku moja au mbili kujaza matanki haya makubwa.”

a) Taja maudhui yoyote matatu yanayojitokeza. (al 3)

i) _____

ii) _____

iii) _____

b) Eleza sifa za wahusika hawa (al 2)

i) Jasiri

ii) Babake Jasiri

c) Mwandishi wa kazi hii alikuwa na dhamira gani? (al 2)

d) Taja tamathali zilizotumiwa katika kazi hii ya fasihi. (al 2)

e) Eleza mandhari ya kazi hii. (al 1)

ZOEZI 4: TAMTHILIA

Soma sehemu ifuatayo ya tamthilia kisha ujibu maswali.

- Mishi:** Kama wanaupenda 'Ukuti wa Mnazi' au mwingineo, hayo ni mapenzi yao. Au unaona kuwa mimi ndiye ninayewapangia nyimbo gani waimbe?
- Mabula:** (*Kwa Sauti ya chini.*) Si lazima kuwapangia lakini unaweza kuwaelekeza wajue la kuimba.
- Mishi:** Mabula!
- Mabula:** Sema.
- Mishi:** Una habari mimi ni nani kwako?
- Mabula:** Sasa swali gani hilo?
- Mishi:** (*Kwa msisitizo.*) La iwapo mimi nani kwako maana ninaona unanifanya mimi prefect wa watoto wanaocheza. Sijui kama ni class prefect, games prefect au music prefect!
- Mabula:** Sasa imekuwa ni hayo?
- Mishi:** Ndiyo haya uliyaanza wewe. Ningekuwa mke kwa maana ya mke usingeniweka kundi sawa na watoto.
- Mabula:** (*Anacheka kicheko kirefu.*) Mishi, ninashindwa kuelewa kwa nini mambo madogo yanakuchenga. Usipowapa watoto mwongozo atawapa nani? Hebu niambie.
- Mishi:** Mwongozo katika michezo ya watoto?
- Mabula:** Mishi, usidharau nguvu za nyimbo. Wanasema mwanzo wa ngoma ni lele.
- Mishi:** Basi kama ni lele, nimeicheza sana hiyo lele!
- Mabula:** (*Ameukinai mjadala.*) Ushindani wa namna hii hauwezi kutufaa kitu. Angalia muda wote huu umekuwa ni mvutano usiokuwa na msingi. Tumeharibu muda mwingi kubishana. Hivi ubishi utatufaa nini?
- Mishi:** Mkuki kwa nguruwe kwa binadamu mchungu! Ingekuwa ni mimi ungetafuta maneno ya kunitwangia. Sasa inapokuwa ni wewe inakuwa ni kupoteza muda. Haya! (*Wanatazamana.*)
- Mabula:** Wewe mwanamke! Umeona wapi mwanamke akimtazama mwanamume namna hiyo? Hata ukope hupepesi! (Bado Mishi amemtazama tu. Analichukulia kuwa tendo la kumdharau.) Nimeona kuwa siku hizi umeanza kuota nundu mgongoni.
- Mishi:** (*Anageuka na kuuelekeza mgongo wake alipo Mabula.*) Nundu iko wapi? Umeiona kweli wewe?

a) Taja maudhui yanayojitokeza katika kazi hii. (al 3)

- i) _____
- ii) _____
- iii) _____

b) Kwa mujibu wa mazungumzo haya, taja sifa za Mabula. (al 2)

- i) _____
- ii) _____

- c) Eleza dhamira ya mwandishi wa kazi hii. (al 2)
 i) _____
 ii) _____
- d) Taja mandhari ya onyesho hili. (al 1)

- e) Bainisha mbinu za lugha alizotumia mwandishi katika onyesho hili. (al 2)
 i) _____
 ii) _____

ZOEZI 5: USHAIRI

(Alama 5)

Soma shairi lifuatalo kisha ujibu maswali

Najiamini nikija, kwa kuwa ninayo hoja
 Niseme na nyie waja, si kwamba nataka koja
 Hoja yangu kama chaja, kumemesha walokuja
 Umoja wetu natija, tule nyama ya kipaja!

Mtoto akizaliwa, asiwe ni wa mumoja
 Mafunzo ni wa kupewa, lisibaki hata moja
 Akikosa kifokewa, iwe kwetu bora hoja
 Kama sahani na kawa, mtoto umoja wetu.

Njiani akitembea, salama yake ni haja
 Kila haki kutendea, kila mja na mkaja
 Mapenzini kubembea, watu wote yake faja
 Kama sahani na kawa, mtoto umoja wetu.

Maradhi yakimsibu, tuwe sisi wa faraja
 Tumfaye matibabu, atuhisi kipambaja
 Tuwe wake matabibu, kupakata kwenye paja
 Kama sahani na kawa, mtoto umoja wetu.

Yake mila kuishika, siachwe awe kushaja
 Kitambulisho hakika, si maneno kuboboja
 Kwa staha akifika, simuone ni kiroja
 Kama sahani na kawa, mtoto umoja wetu.

Huyu mwana kama ngao, mtunze pasi kufuja
 Salama yake uzao, tahadhari sijevuja
 Haki ni wake mgao, apewe kwani mkaja
 Mtoto umoja wetu, tumlinde kila hali!

- a) Lipe kichwa shairi hili. (al 1)

- b) Ujumbe mkuu katika shairi hili ni upi? (al 1)

- c) Taja mbinu mbili za lugha zilizotumika katika shairi. (al 1)

- d) Mwandishi ana maoni yapi ubeti wa pili? (al 1)

- e) Onyesha jinsi mshairi alivyotumia uhuru wake kwenye shairi. (al 1)

Candidate's Name	
School Name	
Candidate's Signature	

Assessment Number	
School Code	
Date	

Time: 1hr 40min

JUNIOR SCHOOL ASSESSMENT GRADE 9 2025

- INTEGRATED SCIENCE -

JESMA 002

INSTRUCTIONS TO CANDIDATES

1. Write your **Name** and **Assessment Number** in the spaces provided above.
2. Write the **Name** and **Code** of your school in the spaces provided above.
3. Sign and write the date of the assessment in the spaces provided above.
4. This questions paper consists of **TWO** sections: **A** and **B**.
5. **Section A** comprises of Multiples Choices Questions numbered **1** to **30**.
6. **Section B** comprises short, structured questions numbered **31** to **41**.
7. Answer **ALL** the questions in **Section A** on the separate **ANSWER SHEET** provided.
8. Answer **ALL** the questions in **Section B** in the spaces provided in this **QUESTION PAPER**.
9. **DO NOT** remove any page from this question paper
10. Answer **ALL** the questions in English.

FOR OFFICIAL USE ONLY

SECTION A

Questions	1- 30
Maximum Score	30
Candidate's Score	
Performance Scale	

SECTION B

Questions	31	32	33	34	35	36	37	38	39	40	41	42	43	44	45
Maximum Score	3	3	3	2	4	3	1	3	3	6	2	2	3	1	1
Candidate's Score															
Performance Scale															

**GRAND
TOTAL**

This paper consists of 8 printed pages.

Candidates should check the question paper to ensure that all the pages are printed as indicated and no questions are missing.

SECTION A: (30 MKS)

- Substances that make up uniformly distributed mixtures are known as _____.
 - Solid-solid mixture
 - Heterogenous
 - Homogenous
 - Liquid-liquid mixture

- Which method of separating mixtures is shown below? _____

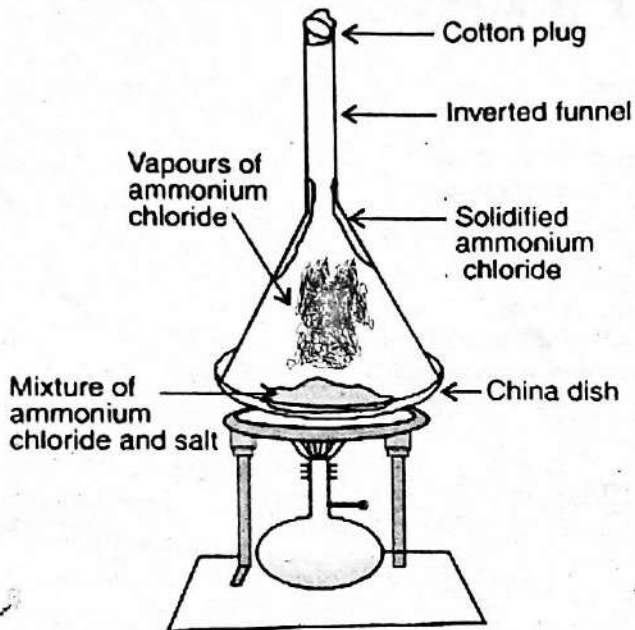

- Crystallization
- Simple distillation
- Sublimation
- Filtration

- The following are characteristics of temporary chemical changes in a substance. Which one is **not**?
 - New substance is formed
 - Heat energy is absorbed and released
 - No new substance is formed
 - It is irreversible

- Which one of the following arrangements represent a fire triangle?
 - Oxygen, hydrogen and light
 - Oxygen, fuel and heat
 - Oxygen, fuel and carbon IV oxide
 - Hydrogen, fuel and light

- The following are importance of using symbols in the laboratory. Which one is **not**?
 - Symbols are easier to remember.
 - They reduce confusion.
 - Create confusion in the laboratory.
 - They give a visual reminder.

- Learners gave reasons why all chemicals must be labelled. Which reason was **incorrect**?
 - For proper storage
 - To easily identify the correct chemical for every experiment
 - To indicate which chemical to eat.
 - Avoid accidents during experiments.

- The following are the **main** layers of the skin. Which one is **not**?
 - Dermis
 - Epidermis
 - Blood vessels
 - Subcutaneous

- Which among the following waste products is **not** excreted through the kidneys?
 - Excess water
 - Excess fats
 - Lactic acids
 - Urea

- The diagram below shows th structure of

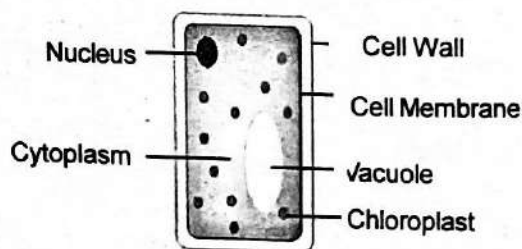

- Plant cell
- Chloroplast
- Animal cell
- Cytoplasm

10. What is the function of the cytoplasm?
- Provides cell with the structure.
 - Contains chlorophyll.
 - Controls sugar and salt concentration.
 - Part where chemical reactions take place.

11. Which among the following is **not** a source of electricity in our environment?

- Wind
- Geothermal
- Electromagnet
- Hydropower

12. What charge is in the nucleus of an atom?

- Positive
- Negative
- Both positive and negative
- Neutral

13. Which one of the following is a non-magnetic material?

- Steel
- Iron
- Aluminium
- Cobalt

14. The following are forms of energy **except**?

- Chemical
- Sound
- Heat
- Temperature

15. A television operates by transforming

- Light → Sound → Electric energy
- Electric → Light → Sound energy
- Sound → Light → Electric energy
- Light → Electric → Sound energy

16. The diagram below shows a certain arrangement in a simple circuit. It is a

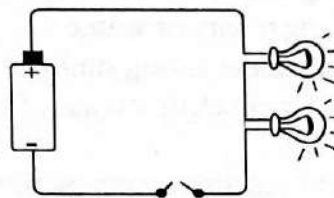

- Simple cells arrangement
- Parallel cells arrangement
- Series cells arrangement
- Wired and bulb cells arrangement

17. The diagram below shows that _____

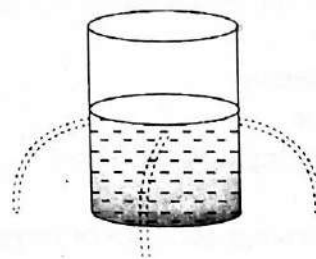

- Pressure in liquids increases with depth.
- Pressure in liquids is exerted equally in all directions at the same depth.
- Pressure in liquids decreases with depth.
- Pressure in liquids is exerted equally in one direction at the same depth.

18. The following are roles of osmosis in living organisms. Which one is **not**?

- Feeding of insect plants.
- Osmoregulation in the kidney.
- Helps in opening and closing of stomata.
- Breathing in and out.

19. Musau used a light microscope to observe a specimen. The objective lens had a magnification power of X40. Calculate the total magnification of the cell.

- X40
- X400
- X4
- X0.400

20. The following lifestyles promote healthy skin **except**
- Bathing at least twice a day.
 - Drinking plenty of water.
 - Basking under strong sunlight.
 - Going for check up in case of anything.
21. The following are classes of fire. Which one is **not**?
- Class B
 - Class D
 - Class Z
 - Class A
22. Which part of the microscope is used to place the specimen for viewing?
- Stage
 - Condenser
 - Mirror
 - Revolving nosepiece
23. The following are roles of oxygen in day-to-day life, **except**
- Combustion
 - Steel making
 - Respiration
 - Lighting
24. Which among the following is a physical property of oxygen?
- It is soluble in water
 - It is less dense than air
 - Has a boiling point of 20°C
 - Has a little odour
25. The following are importance of packaging labels. Which one is **not**?
- Check on proper way of storing the item.
 - To check on the expiry date.
 - Check on the amount of fire to use.
 - Check on the ingredients used.
26. Which of the following consists of sexually transmitted infections which are caused by bacteria?
- AIDS, herpes, syphilis
 - Syphilis, herpes, HIV
 - Gonorrhoea, syphilis
 - Tuberculosis, gonorrhoea
27. The release of female sex cell from the ovary is known as
- Implantation
 - Ovulation
 - Fertilisation
 - Menstruation
28. The following are differences between plant cell and animal cell. Which one is **not**?
- Large in size
 - Have nucleus
 - Animal cells do not have cell wall
 - Plant cells have chloroplast
29. The following are factors affecting osmosis. Which one **does not**?
- Temperature
 - Concentration gradient
 - Type of semi-permeable membrane
 - The type of Perfume used
30. Adolescence developmental challenges can be categorised among the following **except**
- Emotional
 - Personal
 - Physical
 - Social

SECTION B (40MKS)

31. List down **three** properties of gases.

(3mks)

- i) _____
- ii) _____
- iii) _____

32. Name the apparatus labelled in the set up below.

(3mks)

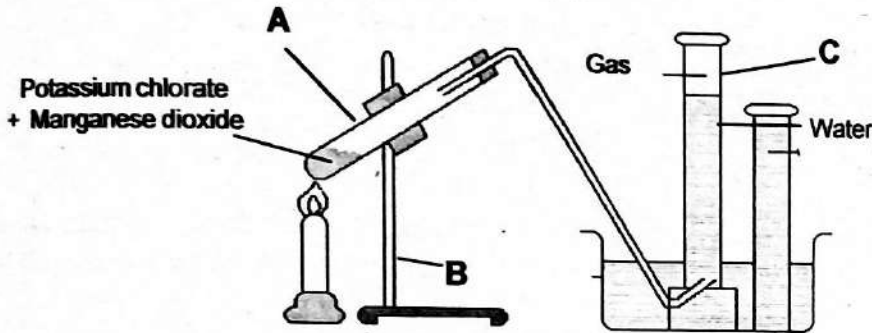

- A - _____
- B - _____
- C - _____

33. Iron is the most commonly used element in the day-to-day life. State **three** of its applications.

(3mks)

- i) _____
- ii) _____
- iii) _____

34. Complete the work equation to represent a type of change on heating Hydrated Cobalt (II) Chloride.

(2mks)

A. Hydrated Cobalt II chloride \rightarrow _____ + _____

B. The type of change represented above is _____

35. State **two** uses of acids and bases in real life.

(4mks)

a) Acids

- i) _____
- ii) _____

b) Bases

- i) _____
- ii) _____

36. The diagram below represents parts of the female reproductive system.
Name the parts labelled 1, 2 and 3.

(3mks)

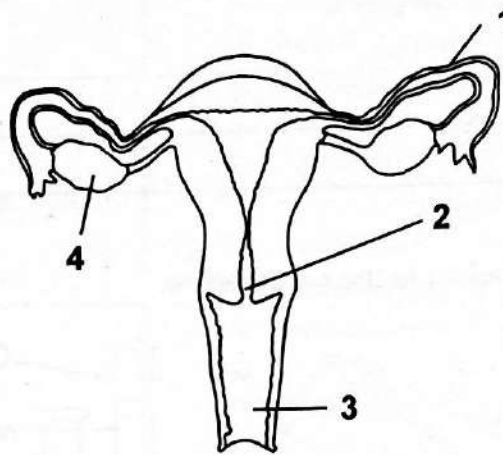

- 1 - _____
2 - _____
3 - _____

37. State the function of the part labelled 4.

(1mk)

38. Write **three** components of urine.

(3mks)

- i) _____
ii) _____
iii) _____

39. State **three** functions of the skin.

(3mks)

- i) _____
ii) _____
iii) _____

40. As the Health CS in your school, you have been directed to talk about kidney disorders.

a) State **three** kidney disorders you will talk about .

(3mks)

- i) _____
ii) _____
iii) _____

b) List **three** prevention measures you will discuss. (3mks)

- i) _____
- ii) _____
- iii) _____

41. State **two** ways of charging objects. (2mks)

42. The diagram below shows structure of an atom.

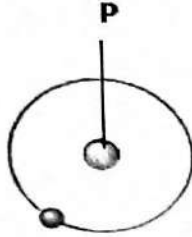

The part labelled **P** contains _____ and _____. (2mks)

43. Pressure exerted by an object depends on the area on which the force is acting. The pictures below show types of shoes.



a) Identify the type of shoes suitable for walking on a sandy ground. _____ (1mk)

b) Explain your answer in (a) above. (2mks)

44. Magnets have different shapes. Name the ones drawn below.

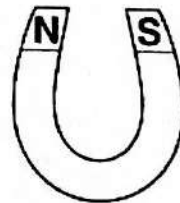
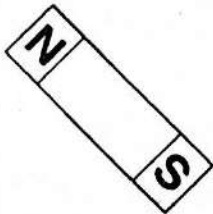

a) _____

b) _____

45. State **one** application of common elements and compounds. (1mk)

Candidate's Name	
School Name	
Candidate's Signature	

Assessment Number	
School Code	
Date	

JUNIOR SCHOOL ASSESSMENT GRADE 9 2025

**JESMA
002**

- AGRICULTURE AND NUTRITION -

**KJSEA
906/1
AGRICULTURE & NUTRITION
Paper 1
Time: 1hr 40 minutes**

INSTRUCTIONS TO CANDIDATES

1. Write your **Name** and **Assessment Number** in the spaces provided above.
2. Write the **Name** and **Code of your school** in the spaces provided above.
3. Sign and write the date of the assessment in the spaces provided above.
4. This questions paper consists of **TWO** sections: **A** and **B**.
5. **Section A** comprises of Multiples Choices Questions numbered **1** to **30**.
6. Section B comprises short, structured questions numbered **31** to **44**.
7. Answer **ALL** the questions in **Section A** on the separate **ANSWER SHEET** provided.
8. Answer **ALL** the questions in **Section B** in the spaces provided in this **QUESTION PAPER**.
9. **DO NOT** remove any page from this question paper
10. Answer **ALL** the questions in English.

FOR OFFICIAL USE ONLY

SECTION A

Questions	1 - 30
Maximum Score	30
Candidate's Score	
Performance Scale	

SECTION B

Questions	31	32	33	34	35	36	37	38	39	40	41	42	43	44
Maximum Score	3	2	1	3	2	4	4	1	3	2	3	3	5	5
Candidate's Score														
Performance Scale														

This paper consists of 7 printed pages.

Candidates should check the question paper to ensure that all the pages are printed as indicated and no questions are missing.

- Contamination of soil with harmful things is known as soil
 - erosion
 - pollution
 - conservation
 - distrubance
- Name the water retention structures below



- Water retention ditches
 - Sunken bed
 - Earth basins
 - Water retention pits
- The following are ways of conserving vitamins and mineral salts in vegetables during handling, preparation and cooking. Which one is **not**?
 - Cutting
 - Washing
 - Boiling
 - Peeling
 - Removal of excess seedlings in a crop field is known as
 - gapping
 - thinning
 - roguing
 - pruning

- Mr. Mmudi, a Nutrition teacher, was teaching his learners factors determining a cooking method. Which one is **not**?
 - Flavor
 - Time
 - Fuel
 - Equipment
- The equipment below is used when roasting meat.

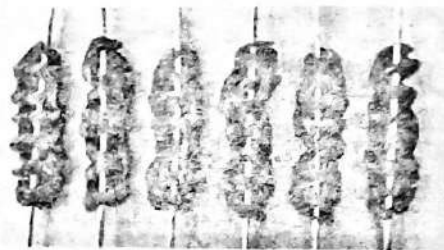

- The equipment is referred to as
- craving board
 - two prong fork
 - skewer
 - tongs
- Grade 7 learners from Hope Academy were collecting materials used in laundering loose-coloured clothes. Which one of the following materials was not collected?
 - Vinegar
 - bleaching agent
 - salt
 - Lemon
 - The process of constructing fabric is known as
 - stitching
 - clothing
 - sewing
 - knitting

9. Patome was researching on methods of adding value to crop produce. Which of the following is a method of adding value to crops?

- A. Storing
- B. Harvesting
- C. Drying
- D. Boiling

10. Grade 8 learners from Migwani Primary went to the nearby market to create awareness among the public on ways of preventing soil pollution. Which of the following means was **not** used?

- A. Poster
- B. Dramatization
- C. Poems
- D. Dancing

11. Planting trees where none existed is known as

- A. deforestation
- B. afforestation
- C. reforestation
- D. agroforestry

12. Which of the following is **not** a method of conserving the agricultural environment?

- A. Stone lines
- B. Trash lines
- C. Over cropping
- D. Soil bunds

13. A plan of how various farm components are arranged and set up in a farm is known as farm

- A. structure
- B. arrangement
- C. model
- D. layout

14. Three of the following are types of water storage tanks **except** one. Which one is it?

- A. Plastic
- B. Rubber
- C. Metallic
- D. Concrete

15. Which of the following is **not** an example of an innovative kitchen garden?

- A. Container
- B. Multi-storey
- C. Seed bed
- D. Wick

16. We get different products from domestic animals. Goats give us meat and milk, meat from goat is called

- A. mutton
- B. chevon
- C. beef
- D. bacon

17. Which material of the compost pit introduces bacteria for decomposition?

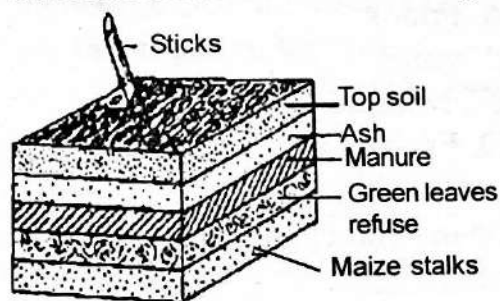

- A. Manure
- B. Top-soil
- C. Ash
- D. Green leaves refuse

18. Which one of the following tools and material is **not** used when making a poultry fold?

- A. Claw hammer
- B. Measuring tape
- C. Wood
- D. Sacks

19. Dharma saw a small wild animal on her farm that was eating her poultry eggs. Which wild animal was it **likely** to be?
 A. Monkey
 B. Squirrel
 C. Mongoose
 D. Mole
20. Name the crop pests that eat the stem of vegetable crops.
 A. Caterpillar
 B. Cutworm
 C. Aphids
 D. Locust
21. Three of the following are methods of preserving meat **except** one. Which one is it?
 A. Salting
 B. Smoking
 C. Fermentation
 D. Sun-drying
22. Which of the following is a planting material?
 A. Ponds
 B. vines
 C. Manure
 D. Fruits
23. Beans and eggs are examples of _____
 A. Energy-giving foods
 B. Protective foods
 C. Bodybuilding foods
 D. Legumes
24. Which one of the following is **not** a type of soil erosion?
 A. Spatter
 B. rill
 C. Contours
 D. gulley
25. Which of the following is an indigenous vegetable crop
 A. Cabbage
 B. Pigweed
 C. Carrots
 D. Kales
26. Joy was studying micronutrients found in the food. Some of the micronutrients she studied were?
 A. Carbohydrates and vitamins
 B. Proteins and carbohydrates
 C. Vitamins and minerals
 D. Proteins and vitamins
27. Name the method used to control sheet erosion.
 A. Terracing
 B. Growing vegetation cover
 C. Tilling the land
 D. Contour farming
28. Farming practices aimed at least disturbances of the soil are known as
 A. Reduced cropping
 B. Minimum tillage
 C. Organic farming
 D. Cover cropping
29. Which of the following is **not** a maintenance practice carried out on crops?
 A. Pruning
 B. watering
 C. earthing up
 D. sowing
30. The **best** way to control weeds in a nursery bed is
 A. digging
 B. uprooting
 C. using chemicals
 D. slashing

SECTION B (40 MARKS)

31. Grade 8 learners from Fortunate Academy were discussing soil conservation activities. Outline **three** soil conservation activities they were **likely** to discuss. **(3mks)**

- i) _____
- ii) _____
- iii) _____

32. Define soil conservation. **(2mks)**

33. Name the method of soil conservation method in the diagram below. **(1mk)**



34. Tracey visited her farm and identified vegetables that were attacked by pests by looking at them. List **three** signs that she observed on the vegetables attacked by pests. **(3mks)**

- i) _____
- ii) _____
- iii) _____

35. Define post-harvest practices in crop management. **(2mks)**

36. Discuss **four** post-harvest practices carried out on vegetables. **(4mks)**

37. Pascal was dressing a poultry carcass. Discuss the practices he carried out to dress the poultry carcass. (4mks)

38. Name the structure below. (1mk)

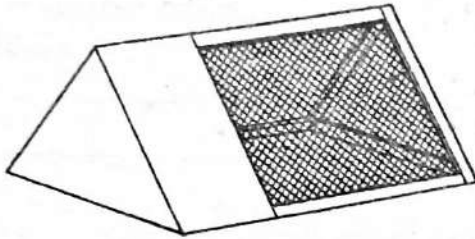

39. Stacey was rearing her poultry in the above structure. Name **three** practices that she carried out when rearing her poultry. (3mks)

- i) _____
- ii) _____
- iii) _____

40. Define a seam (2mks)

41. Name **three** types of seams used in clothing construction (3mks)

- i) _____
- ii) _____
- iii) _____

42. Grade 8 learners were learning qualities of a good seam. Give **three** qualities that they learned. (3mks)

- i) _____
- ii) _____
- iii) _____

43. Ms. Pauline a Grade 8 teacher invited a resource person to teach her learners on methods of cleaning kitchen surfaces. List **five** methods that the learners were taught by the resource person. **(5mks)**

- i) _____
- ii) _____
- iii) _____
- iv) _____
- v) _____

44. Discuss the process followed when processing fresh fish. **(5mks)**

Candidate's Name	
School Name	
Candidate's Signature	

Assessment Number	
School Code	
Date	

JUNIOR SCHOOL ASSESSMENT GRADE 9 2025

JESMA
002

- SOCIAL STUDIES -

KJSEA
907
SOCIAL STUDIES
Time: 1hr 30 minutes

INSTRUCTIONS TO CANDIDATES

1. Write your **Name** and **Assessment Number** in the spaces provided above.
2. Write the **Name** and **Code** of your school in the spaces provided above.
3. Sign and write the date of the assessment in the spaces provided above.
4. This questions paper consists of **two sections: A and B** questions.
5. **Section A** comprises Multiple Choice Questions.
6. **Section B** comprises structured questions and essay questions.
7. Answer **ALL** the questions in **Section A** on the separate **ANSWER SHEET** provided.
8. Answer **ALL** the questions in **Section B** in the spaces provided on this question paper.
9. **DO NOT** remove any page from this question paper
10. Answer **ALL** the questions in English.

FOR OFFICIAL USE ONLY

SECTION A

Questions	1 - 20
Maximum Score	20
Candidate's Score	

SECTION B

Questions	21	22	23	24	25	26	27	28	29	30	31
Maximum Score	6	8	8	7	14	7	6	5	6	4	6
Candidate's Score											

This paper consists of 8 printed pages.

Candidates should check the question paper to ensure that all the pages are printed as indicated and no questions are missing.

SECTION A: (20MKS)

- Grade 9 learners at Juhudi Junior School had a discussion on slavery and servitude. Below are the various forms of slavery and servitude in traditional African society **except** one. Which one?
 - Chattel slavery.
 - Domestic slavery.
 - Pawnship slavery
 - Refuge slavery.
- The time in Monrovia, Liberia 30°W is 4.00pm. Calculate the time in Yaounde, Cameroon 30°E
 - 9.00pm.
 - 8.00pm.
 - 12.00noon.
 - 4.00am.
- Mwanja, a Grade 9 learner visited a local museum to learn more on sources of historical information. Which one among the following is a secondary source of historical information?
 - Books.
 - Scrolls
 - Stone inscriptions
 - Video clips.
- During a Social Studies lesson, Mulati took his group members through a discussion on methods of irrigation used in Ancient Egypt. Below is a description of one of these methods.
 - It uses one principle of levers to lift water from streams into canals.*
 - It is made up of a long pole that is between two wooden parts.*
 - A heavy lad hands on one end of the pole and a bucket on the other end.*The method described above is
 - Archimedian screw method
 - Water wheel method
 - Shadoof method
 - Basin method
- Mr. Wafula asked his learners to research on the political organisation of the Zulu in Africa upto 1900. The learners found out that the Zulu were led by
 - a chief
 - a king
 - an emperor
 - a council of elders.
- During colonial rule in Africa, countries of Africa were divided among the European colonial master. Which one of the following countries of Africa is **correctly** matched with its colonial master?
 - Ghana - British
 - Egypt - French
 - South Africa - Germans.
 - Kenya - Italians
- During a field study by Grade 9 learners to Mavueni area to learn more on the different language groups in the area, the following challenges were encountered **except** one. Which one?
 - Language barrier
 - Lack of writing material.
 - Insufficient funds.
 - Hostile respondents.
- After having a discussion on the various human rights, Mr. Ndegwa asked learners to classify the human right. Which one of the following human rights is an economic right? Right to
 - life
 - vote.
 - own property.
 - clean water.

9. During a class discussion on human origin, Grade 9 learners looked at the reason why Africa is considered the cradle of mankind. Which one of the following is **not**?
- The oldest fossils were found in Africa.
 - Africa has a favourable climate for early man.
 - Africa has many pre-historic sites.
 - Africa has many forests for hunting and gathering.

Study the map of Bondeni Area below and use it to answer questions 10 to 14

BONDENI AREA

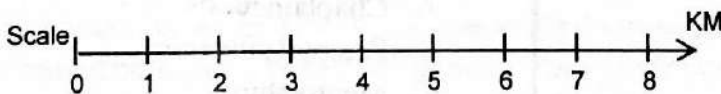
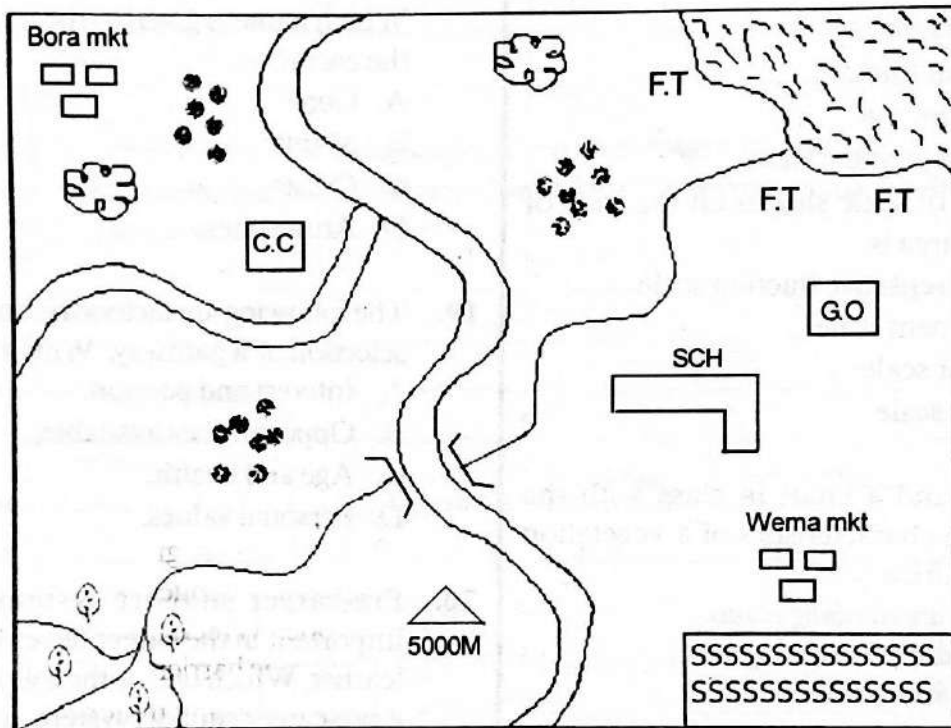

KEY

	Tarmac road		Forest		GO - governor's office
	Murrum road		Quarry		C.C - Chief's office
	River		Settlement		F.T - Fish traps
	Bridge		Mkt - Market		SCH - School
	Permanent Building		SS - Sugarcane farm		

10. The type of settlement pattern in Bondeni area is
- sparse
 - linear
 - clustered
 - nucleated
11. The following economic activities are practiced in Bondeni area **except**
- farming
 - lumbering
 - fishing
 - mining

12. The map of Bondeni area has the following marginal information **except**
- copyright
 - scale
 - key
 - Title
13. The method used to represent marginal information on the map in Bondeni area is
- spot height
 - contour lines.
 - layer tinting.
 - trigonometric station.
14. The type of scale shown on the map of Bondeni area is
- Representative fraction scale.
 - Statement scale
 - Linear scale
 - Ratio scale
15. Mueni hand a chart in class with the following characteristics of a vegetation zone in Africa.
- There are climbing plants.*
 - Trees are tall and evergreen*
 - Trees from canopies*
 - Trees have buttress roots.*
- The method described above is
- Rainforest vegetation
 - Savannah vegetation
 - Mediterranean vegetation
 - Mountain vegetation
16. The following are historical sites and monuments in Africa. Which one is **correctly** matched with the country?
- Giza pyramids- Egypt
 - Fort Jesus - Mali
 - Robben Island - Kenya
 - Timbktu - South Africa
17. The national government of Kenya has three arms. Which one of the following is **not** an arm of the national government?
- Executive
 - Judiciary
 - Legislature
 - Cabinet
18. Grade 9 learners were discussing with their teacher on the structure of the earth. Which name is given to the upper layer of the earth?
- Core
 - Mantle
 - Crust
 - Atmosphere
19. The following are factors to consider in the selection of a pathway. Which one is **not**?
- Interest and passion.
 - Opportunities available.
 - Age and health.
 - Personal values.
20. Pre-career support systems are vey important in the career development of a learner. Which one of the following is **not** a pre-career support system at school?
- Chaplaincy
 - Parental guidance
 - Mentorship
 - Teaching

SECTION B

1. a) Otieno a Grade 9 learner from Nambale Junior School searched the meaning of the term evolution using a digital device. What was his finding? (2mks)

- b) State any **four** changes that took place as a result of human evolution. (4mks)

i) _____

ii) _____

iii) _____

iv) _____

2. a) Wambui, a Grade 8 learner, was discussing with her classmate some of the pre-historical sites where human remains were discovered in Africa. List **four** of the pre-historical sites that they discussed. (4mks)

i) _____

ii) _____

iii) _____

iv) _____

- b) List **four** reasons why Africa is considered as the Cradle of mankind. (4mks)

i) _____

ii) _____

iii) _____

iv) _____

3. a) Grade 9 learners were discussing the contributions of early civilisation to the development of modern world. Write down **four** of the contributions. (4mks)

i) _____

ii) _____

iii) _____

iv) _____

- b) Identify and explain **four** factors that led to the growth of Swahili civilisation along the coast of East Africa. (4mks)

i) _____

ii) _____

iii) _____

4. a) Grade 9 learners were asked by their Social Studies teacher to use digital device to find out some of the factors that can lead to population increase. Write **four** of the factors the learners found out. (4mks)

- i) _____
- ii) _____
- iii) _____
- iv) _____

b) Identify and write down any **three** impacts of population growth in a community. (3mks)

- i) _____
- ii) _____
- iii) _____

c) List and explain **three** types of migrations found in Africa (3mks)

- i) _____
- ii) _____
- iii) _____

5. a) What is the difference in meaning between weather and climate? (2mks)

b) Mr. Ali, a Social Studies teacher invited a resource person to talk about factors that influence climate in Africa. List down **four** factors that were mentioned. (4mks)

- i) _____
- ii) _____
- iii) _____
- iv) _____

Study the map and answer the following questions.

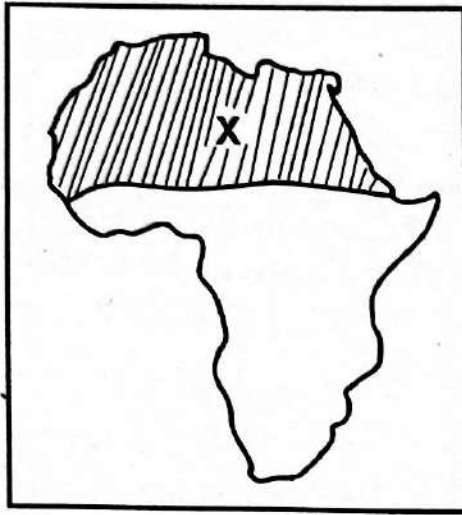

c) Identify and describe the climatic region marked X on the map. (3mks)

d) List down **four** characteristics of the climatic region marked. (4mks)

i) _____

ii) _____

iii) _____

iv) _____

6. a) Define the term career path. (2mks)

b) List down any **three** factors to consider when choosing a career path. (3mks)

i) _____

ii) _____

iii) _____

c) List down **two** learning areas that would be ideal for one aiming to be a banker. (2mks)

i) _____

ii) _____

7. a) What do you understand by **support system** as used in career path? (2mks)

b) Why does one need a support system when choosing a career path? List **two** reasons used in career path? **(2mks)**

- i) _____
- ii) _____

8. a) A school counsellor was talking to be learners about how to build self-esteem. What is the **likey** definition of the word self-esteem that the counsellor gave the learners? **(2mks)**

b) Identify and explain any **three** negative factors that influence self esteem of a person. **(3mks)**

- i) _____
- ii) _____
- iii) _____

9. a) What do you understand by emotional intelligence? **(2mks)**

b) Explain the following terms in emotional intelligence: **(2mks)**

i) Mindfulness:

ii) Journaling: **(2mks)**

10. Njoki is a member of the Environmental Club in her Junior School. She encourages other learners about the importance of being in a clean environment. Njoki exhibits qualities of a global citizen. List down **two** other qualities of a global citizen. **(4mks)**

- i) _____
- ii) _____

11. Identify **three** children's rights as stipulated in the Children's Act 2022 and the African Charter on the rights and welfare of a child. **(6mks)**

- i) _____
- ii) _____
- iii) _____

Candidate's Name	
School Name	
Candidate's Signature	

Assessment Number	
School Code	
Date	

JUNIOR SCHOOL ASSESSMENT GRADE 9 2025

**JESMA
002**

- CREATIVE ARTS AND SPORTS -

KJSEA

911/2

CREATIVE ARTS AND SPORTS (Theory)

Paper 2

Time: 1hr 40 minutes

INSTRUCTIONS TO CANDIDATES

1. Write your **Name** and **Assessment Number** in the spaces provided above.
2. Write the **Name** and **Code** of your school in the spaces provided above.
3. Sign and write the date of the assessment in the spaces provided above.
4. This questions paper consists of **two sections: A and B** questions.
5. Each section has **THREE** parts: **Part I - Performing Arts, Part II - Sports, Part III- Visual Arts**
6. **Section A** comprises Multiple choice questions number: 1- 40.
7. **Section B** comprises short structured and analysis questions 41 to 52.
8. Answer **all** the questions in **Section A** on the separate answer sheet provided.
9. Answer **all** the questions in **Section B** in the spaces provided in this question paper for **Part I - Performing Arts, Part II - Sports, Part III- Visual Arts**.
10. For **Part II - Sports** questions **45 and 46** are **COMPULSORY**. Choose **EITHER** question 47 or 48
11. **DO NOT** remove any page from this question paper
12. Answer **ALL** the questions in English.

FOR OFFICIAL USE ONLY

SECTION A

Questions	1 - 40
Maximum Score	40
Candidate's Score	
Performance Scale	

SECTION B

	Part I: Performing Arts				Part II: Sports			Optional		Part III: Visual Arts		
	41	42	43	44	45	46	47	48	49	50	51	52
Questions	41	42	43	44	45	46	47	48	49	50	51	52
Maximum Score	4	5	6	5	4	4	5	5	4	4	5	10
Candidate's Score												
Performance Scale												

This paper consists of 8 printed pages.

Candidates should check the question paper to ensure that all the pages are printed as indicated and no questions are missing.

SECTION A

PART I: PERFORMING ARTS

1. Which of the followign is **not** the role of performing arts in the society? To
- entertain.
 - educate.
 - bring people together.
 - gossip.

2. What is a dance?
- movement of the body in a rhythmic way.
 - Beat of a song.
 - Written work.
 - Collection of sound.

3. _____ is a combination of sound silence and emphasis.
- Melody
 - Rhythm
 - Harmony
 - Tone.

4. Performing Arts involves performance and presentation to the audience. Which of the following is **not** used when performing?
- Body movement
 - Facial expression
 - Voice expression.
 - Shouting loudly

5. This is the treble clef. What is the other name for it?



- B clef
- G clef
- Bass clef
- F- clef

6. Name the keys marked (i), (ii) and (iii) respectively.



- G A C
- B C F
- D A B
- E G D

7. What is the value of this dotted note?
- 
- 3 quaver beats
 - 2 crochets
 - 3 crotchet beats
 - 1 crochet beats

8. What are the names of the notes written below?



- G DFA
 - ACEG
 - GBDF
 - FACE
9. Which one of the following is a career in the Performing Arts?
- | | |
|--------------|---------------|
| A. Architect | B. Athlete |
| C. Coach | D. Playwright |

10. $\frac{4}{4}$ time in music means
- 4 quaver beats in a bar.
 - 4 crochet beats in a bar.
 - 4 minim beats in a bar.
 - 4 beats ina bar

11. Which one of the following is **not** an element of a play?
- | | |
|------------|--------------|
| A. Theme | B. Character |
| C. Costume | D. Language |

12. In the grand staff, the F-clef and G-clef are joined by a note in the middle of the two staves. What is the name of the note?
- | | |
|----------------|-------------|
| A. Ledger line | B. Middle C |
| C. Bar | D. Tie |

13. In music, note can be increased by a semitone or reduced by a semitone and also it can be restored to its original state. What do we call these symbols?
- | | |
|----------------|-------------|
| A. Accidentals | B. Notation |
| C. Tie | D. Bar |

PART II: SPORTS

14. Learners in Jimbo School were asked to identify careers in the sports. Which of the following careers is **not** related to sports?
- A. Sports coach
 - B. Fitness trainer.
 - C. Performance analysts
 - D. Playwright.
15. These are some of the practices that enhance reaction time. Which one is **not**?
- A. Squat jump
 - B. Ball drop
 - C. Wall jungle
 - D. Crawling
16. Which one of the following is a role of sports in the society?
- A. Physical fitness
 - B. Playing
 - C. Drama
 - D. Sing
17. Learners in Bididi School were practising on the strategies to be used in middle distance race. Which of the following is **not** a strategy?
- A. Running
 - B. Racing
 - C. Recovery
 - D. Stride strength
18. Learners in a school were practising volleyball. Which one of the following is a precaution when playing volleyball?
- A. Never fist the ball as you could hit someone's face.
 - B. Throw the ball over the net.
 - C. Swinger the post
 - D. Jump over the net.
19. What is the work of physical therapist in sports?
- A. Trains the athletes.
 - B. Helps them recover from injuries and improve physical mobility.
 - C. Guides
 - D. Coaches the team.

20. In netball, learners were taught how to do body feigning. What is feigning in netball?
- A. way of confusing or deceiving your opponents through quick body movements.
 - B. Playing of netball.
 - C. Scoring a goal.
 - D. Passing the ball.

21. This is kind of a shot in handball game.



What is the name given to such a shot?

- A. Dive shot
 - B. Jump shot
 - C. Running shot
 - D. Head shot
22. During sports event in a school, the Grade 9 learners were asked to do a long jump hang technique. They performed approach, take off and
- A. Flight
 - B. Running
 - C. Jumping
 - D. Walking
23. The following are some of the warm up activities a learner can get involved before a sports event. Which one is **not**?
- A. Running
 - B. Skipping
 - C. Jogging
 - D. Sitting
24. The below image shows a swimmer.



What kind of swimming style is this?

- A. Breaststroke
 - B. Pencil dive
 - C. Roll back
 - D. Water treading
25. In soccer there are various ways of tackling a player while playing the game. Which of the following is one of the tackles?
- A. Slide tackle
 - B. Front tackle
 - C. Back tackle
 - D. Moving tackle.

26. In basket ball there are various shots a play can use while playing. The shot used when the player is stationary position is known as
- A. jump shot B. dive shot
C. set shot D. lay-up shot.

PART III: SPORTS

27. In visual there are various categories which one can undertake as a career. Among the ones below which one is the odd one out?
- A. Teacher B. Sculptor
C. Illustrator D. Coach.
28. A learner was asked by her teacher to make an artwork by cuttnig and pasting images onto a surface. What type of artwork was the learner making?
- A. Painting B. Mosaic
C. Collage D. Montage.
29. Who is an Art Curator in Visual Arts?
- A. The person in charge of an art exhibition.
B. The person who makes the artworks
C. An artist
D. A person who buys artworks.
30. Colours which are opposite each other on the colour wheel are known as
- A. Tertiary colours
B. Analogous colours
C. Primary colours
D. Complimentary colours.
31. A method creating rapid or fast display still images to create an illusion movement is called
- A. flip book B. Animation
C. Frame D. Speed

32. What is the name of the pattern below?



- A. Pattern
B. Repeat pattern
C. Alternate repeat pattern
D. Motif
33. There are different types of colours when painting. Some colours are warm and other cool. Which of the following shows the cool colours?
- A. Red, orange B. Blue, white
C. Black, yellow D. Purple, red
34. Which one of the following is not a principle of Art?
- A. Proportion B. Dominance
C. Texture D. Balance
35. In photograph there are different views in which a picture can be taken. Which one of the following is not a positoin of taking photographs?
- A. Bird's view B. Normal view
C. Front view D. Worm's view
36. What is a logo design?
- A. A symbol to show case products.
B. Symbol used to identify an individual.
C. For buying products.
D. For display of products.
37. In modelling using clay, various techniques are used. Of the following which one is the odd one out?
- A. Coil B. Coil and stitch
C. Slab D. Pinch
38. What is drawing in visual arts?
- A. colouring of artworks.
B. Making marks on a surface using dry media.
C. Applying paint on paper.
D. Creating artworks.

39. Kigoi Primary School were doing a project of making a javelin to be used during their sports day by using wood. Which are some of the method did they use to decorate the javelin?
- A. Cutting and pasting
 - B. Incising/Polishing
 - C. Carving
 - D. Modelling

40. Who is sculptor? A person who
- A. makes sculptures.
 - B. makes pots.
 - C. makes sign.
 - D. cuts wood.

SECTION B

PART I: PERFORMING ARTS

41. a) Identify two elements of a verse. (2mks)
- i) _____
- ii) _____

- b) Write the corresponding notes on the bass staff on the spaces as shown below. (2mks)

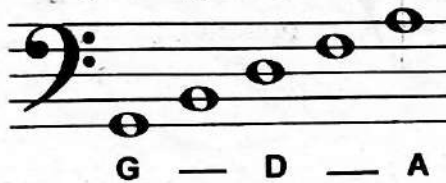

42. a) In music we use accidentals to raise the pitch of a note, lower it or to restore a note to its natural state. Write down **three** names of the accidentals and their corresponding signs. (3mks)

- i) _____
- ii) _____
- iii) _____

- b) When performing music, we use different hand signs to show a particular note. Draw the hand signs representing the notes doh and la? (2mks)

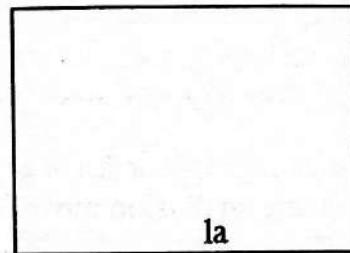
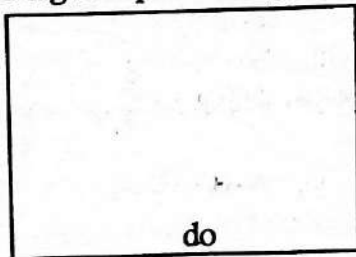

43. a) Rhythm is a pattern of sound, silence and emphasis in a song. Write down the names of notes represented by the rests below. (2mks)

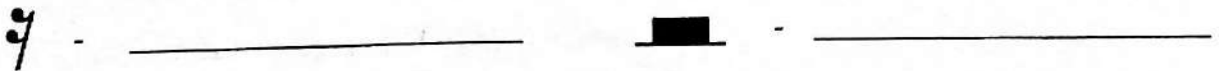

- b) Write down the French rhythm names associated to the following dotted notes (2mks)

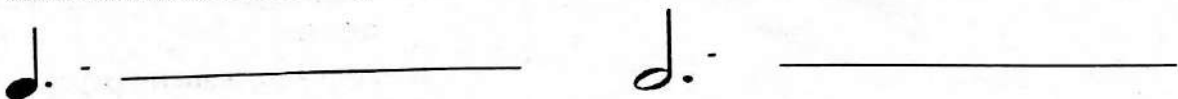

c) A descant recorder is played by using various techniques. Describe the techniques.

i) Tonguing

(2mks)

ii) Fingering

(2mks)

44. a) We use different symbols in music in order to get the correct interpretation on how to sing a particular part or phrase. What do the symbols below mean? (2mks)

i)



ii)



b) Write down three factors which you can use to classify the Kenyan folk dances. (3mks)

i)

ii)

iii)

PART II: SPORTS

45. a) In physical fitness you need to adhere to the main key components of physical fitness. Which ones are they? (2mks)

i)

ii)

b) Kamau was planning to take part in the olympics this year. He was practising for the middle distance races. Give two examples of such races (2mks)

i)

ii)

46. a) The picture below shows a netball player passing a ball. What is the name of this pass? (2mks)

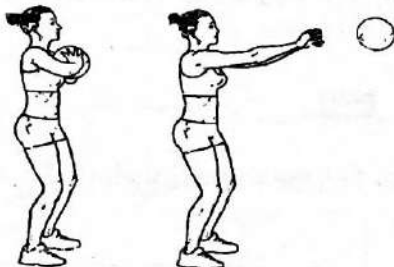

b) Before performing or taking part in volleyball, one needs to do some warm up activities before engaging in playing. Write down **two** warm up activities for volleyball playing for over arm serve. **(2mks)**

i) _____
ii) _____

47. In swimming using the inverted breaststroke, there are various performances one needs to undertake. Write in short , what you need to do to perform well in the swimming. **(5mks)**

48. During a netball game Rita wanted to catch a ball from her teammate. Which are some of the landing skills she did while landing? **(5mks)**

49. a) In learning Creative Arts and Sports, we learn about the various roles it plays in the society. List down **three** roles it plays. **(2mks)**

i) _____
ii) _____

b) Players in netball playing, practice the use of footwork as a way of moving and passing the ball. Name **two** kinds of footwork used in netball. **(2mks)**

i) _____
ii) _____

50. a) An artist wanted to create an artwork by drawing and painting. During the process, he used various principles of art. List **two** principles. **(2mks)**

i) _____
ii) _____

b) Montage artwork is made by cutting and pasting of related image. Which are some the elements to consider when making the artwork? List **two**. **(2mks)**

i) _____
ii) _____

51. a) Mary wanted to decorate a fabric by using a stencil to create a pattern. What kind of pattern did she create? **(2mks)**

i) _____
ii) _____

b) John would like to pursue a career in Visual Arts though he has not decided which one. **(3mks)**
Suggest two careers for him.

i) _____

ii) _____

52. Draw or paint a still life composition from imagination of your own choice. The composition can either be shaded or painted. **(10mks)**

Judging will be done as follows:

- a) Use of $\frac{3}{4}$ of the drawing space.
- b) Overlapping of forms (placement)
- c) Use of a wide range of values to create a 3D forms
- d) The skill of shading or painting.
- e) Neatness

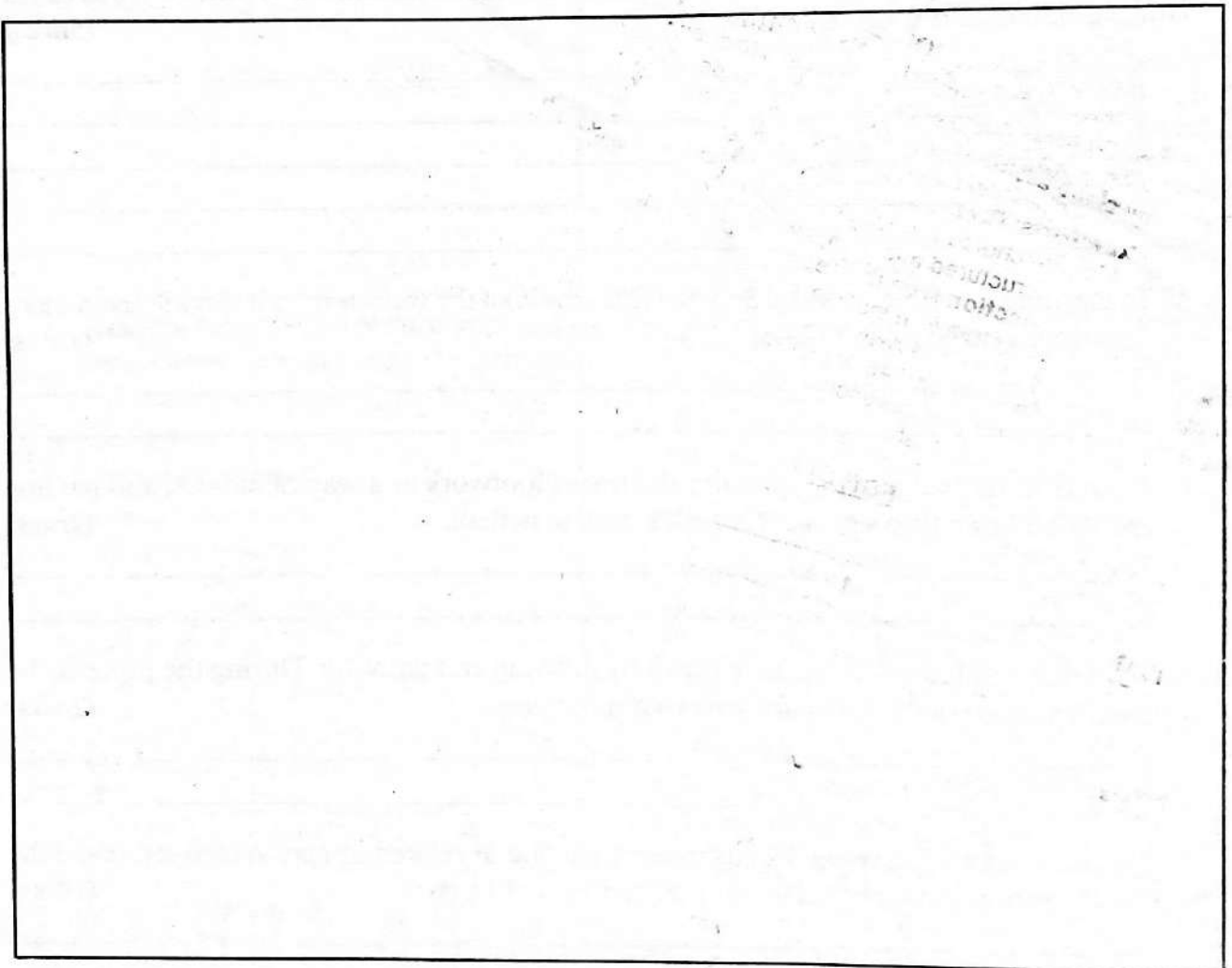

Candidate's Name	
School Name	
Candidate's Signature	

Assessment Number	
School Code	
Date	

JUNIOR SCHOOL ASSESSMENT GRADE 9 2025

- RELIGIOUS EDUCATION -

**JESMA
002**

**KJSEA
908
CHRISTIAN RELIGIOUS EDUCATION
Time: 1hr 30 minutes**

INSTRUCTIONS TO CANDIDATES

1. Write your Name and Assessment Number in the spaces provided above.
2. Write the Name and Code of your school in the spaces provided above.
3. Sign and write the date of the assessment in the spaces provided above.
4. This questions paper consists of two sections A and B.
5. Section A comprises multiple choice questions.
6. Section B comprises short structured and essay questions.
7. Answer ALL questions in Section A on separate answer sheet provided.
8. Answer ALL the question in Section B in the spaces provided in this QUESTION PAPER.
9. DO NOT remove any page from this question paper
10. Answer ALL the questions in English.

FOR OFFICIAL USE ONLY

	SECTION A	SECTION B														
Questions	1-15	16	17	18	19	20	21	22	23	24	25	26	27	28	29	30
Maximum Score	15	2	2	2	2	2	2	2	6	2	2	2	4	2	2	1
Candidate's Score																

**KJSEA
909
ISLAMIC RELIGIOUS EDUCATION
Time: 1hr 30 minutes**

	SECTION A	SECTION B									
Questions	1-15	16	17	18	19	20	21	22	23	24	
Maximum Score	15	5	3	2	5	3	4	4	4	5	
Candidate's Score											

This paper consists of 8 printed pages.

Candidates should check the question paper to ensure that all the pages are printed as indicated and no questions are missing.

CHRISTIAN RELIGIOUS EDUCATION

SECTION A (15 MARKS)

1. _____ in the act of praying on behalf of other people.
 - A. Thanksgiving prayer
 - B. Petition prayer
 - C. Intercessory prayer
 - D. Prayer of dedication
2. Which one is **not** a gift of the Holy Spirit?
 - A. Speaking in tongues.
 - B. Peace
 - C. Wisdom
 - D. Prophecy
3. Who promised the disciples the gift of the Holy Spirit?
 - A. Jesus Christ
 - B. Paul
 - C. Apollos
 - D. God
4. Where were the believers when the Pentecost came?
 - A. Nazareth
 - B. Jerusalem
 - C. Corinth
 - D. Rome
5. Which of the following is **not** a way of showing kindness to the needy?
 - A. Feeding the hungry
 - B. Visiting the people in prison
 - C. Taking care of the sick
 - D. Taking needy people's property
6. One day, Jane's classmate came to school late. During lunchtime, she told her friends that she did not take breakfast and that she did not have anything for lunch. How were they supposed to help her?
 - A. Encourage her to fast and pray
 - B. Share with her what they had
 - C. Ask her to go and join the rest in the field.
 - D. Report her to the teacher
7. Which one of the following is a source of conflict in today's society?
 - A. Fidelity
 - B. Honesty
 - C. Poor communication
 - D. Loyalty
8. The following are some of the places you should stay away from to avoid sexual abuse **except**
 - A. Church
 - B. Abandoned buildings
 - C. Corridors
 - D. Bars and clubs
9. Which is **not** a cause of early pregnancies among teenage girls in the society today?
 - A. Poverty
 - B. Forced marriages
 - C. Peer pressure
 - D. Female genital mutilation
10. The following are values and skills needed to avoid irresponsible sexual behaviour **except**
 - A. Self respect
 - B. Fear of God
 - C. Self control
 - D. Jealous
11. Who killed his brother after his sacrifice was rejected?
 - A. Cain
 - B. Moses
 - C. Elijah
 - D. Adonijah
12. Which one is **not** a cause of bullying schools?
 - A. Revenge
 - B. Physical differences
 - C. Religious differences
 - D. Different sexualities

13. Kioko likes bullying other learners school because he is strong. What value would you advise him to practice?

- A. Forgiveness
- B. Love
- C. Perseverance
- D. Peace

14. Which of the following is **not** a bible teaching about work?

- A. Laziness causes poverty and hardwork causes wealth
- B. A lazy person should not eat more
- C. After work one should have a rest
- D. We work to earn a living

15. Which one is a virtue related to Christian work ethics?

- A. Forgiveness
- B. Love
- C. Perseverance
- D. Peace

SECTION B (35 Marks)

16. Dennis a Grade 9 learner wants to relate well with his fellow students. Explain **two** ways in which CRE can help him achieve this. **(2mks)**

- a) _____
- b) _____

17. The first and second account of creation stories are very different. Explain any **two** ways in which they differ. **(2mks)**

- a) _____
- b) _____

18. In Kenya, the Bible is used to bring holistic growth of a person. Explain any **two** ways the Bible can do so. **(2mks)**

- a) _____
- b) _____

19. Outline any **two** social changes that occur in both boys and girls during adolescent. **(2mks)**

- a) _____
- b) _____

20. Grace, a Grade 9 learner has been meeting online friends and chatting with them through social media. Outline any **two** dangers that she is likely to face **(2mks)**

- a) _____
- b) _____

21. After sinning by man, there are several consequences that befall man. Explain any **two** of them. (2mks)

a) _____

b) _____

22. Nowadays people make a lot of covenant in the society we live in. Give any **two** examples of ungodly covenants (2mks)

a) _____

b) _____

23. Describe the healing of blind Bartimaeus by Jesus Christ. (6mks)

24. Neema a Grade 9 learner who is an orphan is going through a lot challenges in her life. Name any **two** ways in which she can involve God through her challenges. (2mks)

a) _____

b) _____

25. List any **two** church activities that you can engage in as a Christian learner to promote responsibility. (2mks)

a) _____

b) _____

26. Outline any **two** ways by which a Christian can help the needy in the society. (2mks)

a) _____

b) _____

27. Give any **four** ways of overcoming peer influence as a Christian learner (4mks)

a) _____

b) _____

c) _____

d) _____

28. There are several consequences of involving in irresponsible sexual behaviour among young people today. List down any **two** of them (2mks)
- a) _____
- b) _____
29. Outline any **two** ways of discovering ones gift, talents and abilities. (2mks)
- a) _____
- b) _____
30. Give any reason that can lead one to misuse time among youths today. (1mk)
- _____

ISLAM RELIGIOUS EDUCATION

SECTION A (15 MARKS)

- | | |
|---|---|
| <p>1. Juma a Grade 9 learner was discussing about pillars of prayers to his younger brothers. Which one is not a pillar of a prayer?</p> <p>A. Qiraat
B. Quunut
C. Rukuu
D. Sujud</p> <p>2. The language of the Quran is</p> <p>A. Persian
B. Hebrew
C. Classical Arabic
D. Aramaic</p> <p>3. Muslims believe in the fundamental articles of faith. Which one is not? Belief in</p> <p>A. Shahada
B. devine books
C. Qadar
D. the last day</p> | <p>4. During an IRE lesson, teacher Zakiya was teaching on need of revelation of Quran. Which one is not the reason why man needed revelation of the Quran?</p> <p>A. Since the earlier books were distorted.
B. To guide man to the right path.
C. To lead man out of shirk.
D. Since Quran was poetic in nature.</p> <p>5. Which one of the following drugs is referred to as mother of all evils?</p> <p>A. Miraa
B. Alcohol
C. Muguka
D. Tobacco</p> <p>6. Who among the prophets of Allah (S.W.T) is not among the Ulul Azm prophets?</p> <p>A. Ibraim (A.S)
B. Ilyasa (A.S)
C. Noah (A.S)
D. Musa (A.S)</p> |
|---|---|

7. Khulu is a type of divorce sought by the wife. Below are some of the steps in it.
- Application to the court
 - Annulment of the marriage
 - Hearing and examination
 - Consultation with the experts
 - Court decision.
- Arrange the above steps in order
- i), iv), v), iii), ii)
 - i), ii), iii), iv), v)
 - iv), i), iii), v), ii)
 - iv), iii), i), ii), v)
8. Which of the following is among the Khulafa Ur-Rashiduun?
- Umar Ibn Yasir (R.A)
 - Uthuman Ibn Affan (R.A)
 - Abdulrahman Ibn
 - Marwan Ibn Haka
9. Islam prohibits Zinaa. Below are the causes of Zinaa **except**
- Separation between the opposite sex
 - Constant looking at pornographic pictures
 - Free mixing with opposite sex
 - Indecent dressing according to Islam
10. Harith a Grade 9 learner was very annoyed with his classmates. Three of the following are ways he can use to reduce anger **except**
- Remain silent
 - Perform Wudhu
 - Changing position
 - Fighting back
11. Which of the following is **not** a way of preventing covid-19 in a school set up?
- Regular washing of hands
 - Playing soccer
 - Wearing mask
 - Keeping social distance in class
12. In groups Grade 9 learners were told to discuss earlier scriptures before Quran
- Group A - Injeel, Psalms, Taurat, Zabour
 Group B - Quran, Suhuf, Zabour, Taurat
 Group C - Taurat, Zabour, Suhuf, Injeel
 Group D - Zabour, Torah, Quran, Injeel
- Which group gave the **correct** answer?
- Group B
 - Group C
 - Group A
 - Group D
13. The following are the **most** authentic books of Hadith. Which one is **not**?
- Sahih Muslim
 - Sunan Abu Daud
 - Sahih Burhan
 - Sunan Ibn Majah
14. Which of the following is the **main** purpose of morality in Islam?
- Repentance
 - Worship in sincerity
 - Develop Taqwa
 - Promote uprightness
15. The following are prayer performed under special occasions **except** Swalatul
- Asr
 - Musafir
 - Janaza
 - Kusuf

SECTION B (35 MARKS)

16. Identify **five** recipients of Zakat according to the Quran **(5mks)**

- a) _____
- b) _____
- c) _____
- d) _____
- e) _____

17. State **three** legitimate ways in which Muslims should spend their income. **(3mks)**

- a) _____
- b) _____
- c) _____

18. Akida is preparing to go for Hajj. Mention any rites of Hajj that she must fulfil for her Hajj to be accepted. **(2mks)**

- a) _____
- b) _____

19. Discuss any **five** teachings Muslim can learn from Suratul Luqman verses 12-19. **(5mks)**

- a) _____
- b) _____
- c) _____
- d) _____
- e) _____

20. Mention **three** causes of deviant sexual behaviour in your community. **(3mks)**

- a) _____
- b) _____
- d) _____

21. Maria and Hassan lived as husband and wife. Unfortunately, Hassan divorced her. List **four** possible causes of conflict in their marriage **(4mks)**

- a) _____
- b) _____
- c) _____
- d) _____

22. Explain four reasons why Muslims need Hadith in their daily activities. (4mks)

- a) _____
- b) _____
- c) _____
- d) _____

23. Ust Ramadhan from a nearby mosque was called to discuss on the types of Saum in Islam. Highlight any five types of Saum in Islam (4mks)

- a) _____
- b) _____
- c) _____
- d) _____
- e) _____

24. Describe five socio -religious conditions of Arabs during the Pre-Islamic Arabia. (5mks)

- a) _____
- b) _____
- c) _____
- d) _____
- e) _____

Candidate's Name	
School Name	
Candidate's Signature	

Assessment Number	
School Code	
Date	

JUNIOR SCHOOL ASSESSMENT GRADE 9 2025

**JESMA
002**



- PRE-TECHNICAL STUDIES -

**KJSEA
911/1
PRE-TECHNICAL STUDIES
Paper 1
Time: 1hr 40 minutes**

INSTRUCTIONS TO CANDIDATES

1. Write your **Name** and **Assessment Number** in the spaces provided above.
2. Write the **Name** and **Code** of your school in the spaces provided above.
3. Sign and write the date of the assessment in the spaces provided above.
4. This questions paper consists of **two sections: A and B** questions.
5. Each section has **THREE** parts: **Part I - Performing Arts, Part II - Sports, Part III- Visual Arts**
6. **Section A** comprises Multiple choice questions number: 1- 40.
7. **Section B** comprises short structured and analysis questions 41 to 52.
8. Answer **all** the questions in **Section A** on the separate answer sheet provided.
9. Answer **all** the questions in **Section B** in the spaces provided in this question paper for **Part I - Performing Arts, Part II - Sports, Part III- Visual Arts.**
10. For **Part II - Sports** questions **45 and 46 are COMPULSORY.** Choose EITHER question 47 or 48
11. **DO NOT** remove any page from this question paper
12. Answer **ALL** the questions in English.

FOR OFFICIAL USE ONLY

SECTION A

Questions	1 - 30
Maximum Score	30
Candidate's Score	
Performance Scale	

SECTION B

Questions	1	2	3	4	5	6	7	8	9	10	11	12	13	14
Maximum Score	2	4	3	2	3	6	4	3	3	3	8	3	2	4
Candidate's Score														
Performance Scale														

This paper consists of 8 printed pages.

Candidates should check the question paper to ensure that all the pages are printed as indicated and no questions are missing.

Website: www.jesmapublishersltd.com

E-mail: info@jesmapublishersltd.com/jesmapublishers@yahoo.com

002 © Jesma Publishers & Educational Boosters Ltd. Tel: 0701545759/0794677748

TURN OVER

Junior School Assessment

1

Grade 9 Pre-technical Studies 002

SECTION A (30 MKS)

- Which of the following answers **best** shows the difference between a sketch and a drawing?
 - There is no difference between a sketch and a drawing.
 - A drawing can be done in any medium while a sketch is always done in pencil.
 - A drawing is more detailed than a sketch.
 - A sketch is more detailed than a drawing.
- What is the importance of observing safety rules in a workshop? To
 - avoid accidents and injuries
 - impress others
 - keep workshop tidy
 - follow procedures
- What is the primary concern regarding collection of personal data by social media platforms? It
 - helps improve user experience.
 - can be used to target advertisements.
 - can lead to privacy breaches and identity theft.
 - is necessary for platform functionality.
- Imagine you are a team of architects and graphic designers tasked with designing a new skateboard park for your town. You will need both artistic and technical drawings to create your vision to life. Which type of drawing would be used to accurately measure and plan the layout of skate park, including ramps, rails and obstacles?
 - Artistic Drawing
 - Technical Drawing
 - Line Art Drawing
 - Sketch Drawing
- After repairing a bicycle, Maria decided to test ride it. What should Maria prioritize during the test ride?
 - Speed
 - Safety
 - Style
 - Noise
- Leon wants to design a computer game. Which of the following software would be **best** suited to create the graphics?
 - Graphics editing software
 - Spreadsheet
 - A web browser
 - A word processor
- Using visual programming Scratch Coding, Eddy created the graphics, but the game was too slow. What could have been the reason? The
 - computer was too old
 - game had too many colours
 - game had too many sounds
 - game had too many complex calculations.
- What are the basic tools used in technical drawing?
 - Pencils, rulers, and compasses.
 - Paint brushes and canvas.
 - Hammers and nails.
 - Chisels and screw drivers.
- What is the role of a technician? To
 - design new products.
 - conduct scientific research.
 - apply technical skills to solve problems.
 - teach others about technology.
- The following statements shows how technology has imparted the society today **except** it has
 - made life simpler and more efficient.
 - created new jobs and industries.
 - improved communication and transportation.
 - increased robbery with violence.

11. Grade 9 learners engaged in a discussion about regular maintenance of raised platforms. How often should raised platforms be inspected for safety?
- On monthly basis
 - Before each use
 - Once a year
 - Every six months
12. Which of the following is NOT a common material used for constructing raised platforms?
- Wood
 - Metal
 - Concrete
 - Glass
13. What is the **main** reason of using a ramp to access a raised platform? To
- add a decorative element to the platform.
 - provide easier access for people with disabilities.
 - make the platform more visually appealing.
 - reduce the overall cost of construction.
14. A Junior school teacher is talented in Music and wants to start a band in a school. What is first step that should he should take?
- Buying expensive musical instruments.
 - Practicing for hours every day.
 - Finding other musicians who share the same passion.
 - Recording a demo without any practice.
15. It is important for an entrepreneur to be persistent in order to
- give up easily when faced with challenges.
 - avoid taking risks.
 - keep trying even when things get tough.
 - rely on others to solve problems.
16. Why is it important for an entrepreneur to be a good communicator? To
- avoid talking to customers.
 - effectively convey ideas and persuade others.
 - keep information to oneself.
 - ignore feedback and suggestions.
17. How can bookkeeping help businesses identify potential problems? By
- ignoring financial trends.
 - recognising financial patterns.
 - avoiding financial analysis.
 - neglecting financial forecasts.
18. The role of bookkeeping in securing loans and investments is to
- hide financial information.
 - avoid financial transparency.
 - neglect financial accountability.
 - provide accurate financial statements.
19. Which type of software is used to create presentations?
- Word processing software
 - Spreadsheet software
 - Presentation software
 - Database software
20. Which software is commonly used for creating and editing digital images?
- Microsoft Excel
 - Adobe Photoshop
 - Mozilla Firefox
 - Open Office Writer

21. Which one of the following is arranged from the largest to the smallest?
- Main Frame Computers → Mini Computers → Micro Computers → Super Computers
 - Super Computers → Main Frame Computers → Mini Computers → Micro Computers
 - Super Computers → Main Frame Computers → Mini Computers → Micro Computers
 - Mini Computers → Main Frame Computers → Super Computers → Micro Computers
22. What is the difference between software and hardware?
- They are both components of a computer.
 - Software are free hardware is bought
 - Software are non-tangible components of a computer while hardware is tangible.
 - Hardware are computer applications and software is computer apps.
23. Which of the following is **not** a safety precaution while handling corrosive substances?
- Dispose of corrosive waste properly.
 - Work is enclosed room without ventilation.
 - Store corrosive substances in designated containers and areas.
 - Always wear appropriate personal protective equipment.
24. Which of the following is a good quality of an entrepreneur?
- Does not take risks.
 - Resilience
 - Visionary
 - Innovative
25. Who is an entrepreneur? A
- person who buys and sells items to make profit.
 - retailer.
 - wholesaler
 - A person who identified a need or opportunity and risks to start a business to address it.
26. Which of the following is **not** a reason for starting a business?
- Personal growth and fulfillment.
 - Financial independence.
 - Opportunity and innovation.
 - To be above everybody.
27. Which of the following is **false** about ceramic materials?
- Exceptional hardness.
 - Brittleness
 - High thermal expansion.
 - High melting point.
28. Grade 9 learners uses a jack plant for planing a piece of wood. Which of the following is the correct way of protecting the sharp edge of the blade of the plant when storing? Store the plane with the
- blade facing upward
 - blade tightened.
 - body lying on the side.
 - blade flat on the surface.
29. An entrepreneur prefers making money transactions through mobile phone Which one of the following measures can he use to secure the transactions details from unauthorised access?
- Installing antivirus software.
 - Backing up data.
 - Using strong passwords
 - Locking the mobile phone in a drawer.
30. Sources of income are classified into passive and active sources. Identify an active source from the following sources.
- Wages
 - Dividend
 - Interest
 - Rent

SECTION B Weight 50 Marks

1. During a Pre-technical lesson, learners were required to mention types of circles. State **two** types that they mentioned? **(2mks)**

(i) _____
(ii) _____

2. a) Identify of the following tools. **(4mks)**

Tool A



Tool B



Tool C



Tool D



- b) State the use of tools labelled A and C.

3. Outline **three** reasons why studying Pre-Technical Studies is important. **(3mks)**

(i) _____
(ii) _____
(iii) _____

4. Differentiate between artistic and technical drawing? **(2mks)**

5. Apart from scratch, what other examples of visual programming applications do you know? **(3mks)**

(i) _____
(ii) _____
(iii) _____

6. Grade 9 learners from Nexus Academy were to discuss various classifications of computers. Complete the table below with examples of computers in each classification (6mks)

Computer classified according to size	Computer classified according to purpose	Computer classified according to functionality

7. A Grade 9 learner was asked to identify the items listed on the table below and indicate if they were a good or services in the table below. (4mks)

Items	Goods	Services
Teaching		
Furniture		
Security		
Food		

8. Timothy plans on building a house. What **three** factors will he have to consider when setting financial goals for building the house? (3mks)

- (i) _____
- (ii) _____
- (iii) _____

9. There was a conflict within Patanisho Ltd due to misleading information on the duties delegated. The organisation was forced come up with ways to effectively communicate issues. Outline **three** ways of using effective communication in a business? (3mks)

- (i) _____
- (ii) _____
- (iii) _____

10. Match the meaning of online safety threats with the correct meaning in bracket. (3mks)
(Hacking, Cyber bullying, Phishing)

(i) Tricking people online to steal their personal information.

(ii) Hurting or upsetting someone using the Internet.

(iii) Acquiring peoples personal information online without their consent.

11. Explain the following functions of Scratch.

(8mks)

(a) Motion

(b) Costume.

(c) Coding area

(d) Palette

12. Maria, a book seller, had the following balances for the year ending 31st December 2024.

Revenue for the year	60,000
Cost of sales	20,000
Rental Cost	6,000
Salaries	20,000
Transport expenses	1,500

Prepare a simple Income Statement for Maria for the year ending 31st December 2024.

(3mks)

13. A pretechnical studies teacher created the following instruction for determining learner's achievement in an assessment.

Scores > 60: learner is meeting expectation

Scores < 60: learner is approaching expectation

Instructions: Start

```
Enter Score
If score > 60
    Output X
Else
    Output Y
End
```

Complete the results of

(2mks)

X - _____

Y - _____

14. Free hand sketches are drawing made without drawings instruments. For freehand oblique sketch of a cube whose side is 3.0cm, what will be the size of the receding side if it is to be drawn in oblique cabinet? **(4mks)**

JUNIOR SCHOOL ASSESSMENT
GRADE 9 2025
MARKING SCHEME

MATHEMATICS

1. C 6. B 11. A 16. B
2. B 7. C 12. B 17. D
3. B 8. A 13. D 18. B
4. A 9. C 14. A 19. C
5. D 10. D 15. C 20. A

21. Check number line
22. $\frac{3}{5}, \frac{2}{5}, \frac{7}{20}, \frac{3}{40}$
23. $5\frac{65}{72}$ 24. $3\frac{4}{33}$

25. a) 3.21×10^0 b) $1.03 \times 10 = 0.00103$
26. sh. 960
27. a) 2:3 b) Anyona's
28. 144 bags
29. (a) 6y (b) 48 years
30. $x=4, y=3$

31. (b) =sh.300, g=sh.200
32. 5m
33. 28.6cm
34. $154m^2$
35. (a) $868.1472m^2$ (b) $868.1m^2$
36. (a) Sh. 63,000 (b) Sh. 3,000
37. (a) Sh. 49, 920 (b) Sh. 349,920
38. (a) 125° (b) 4.1cm

39. 2.5cm
40. (a) 510 bags (b) 60bags (c) 90 bags

ENGLISH

1. C 11. A 21. D 31. A 41. D
2. A 12. A 22. A 32. B 42. A
3. C 13. B 23. C 33. D 43. D
4. B 14. A 24. B 34. C 44. B
5. D 15. C 25. D 35. B 45. C
6. A 16. D 26. C 36. C 46. D
7. D 17. C 27. A 37. A 47. B
8. A 18. A 28. D 38. D 48. B
9. C 19. B 29. B 39. A 49. A
10. B 20. D 30. C 40. C 50. C

PAPER 2
TASK 2

1. A secret feast
2. Excited/eager
3. Cunning/witty/tricky/willy
4. He was a greedy animal, easy to trick into danger through food
5. There was no food
6. He was almost killed by lion
7. We should not fall prey to our friends so easily
8. Trickster narrative/ tale
9. (a) A confident person; one who is burdened by his past or inability.
(b) Strange change, vow-now, best-rest, light- bright, land-land.
(c) I'm proud of, I love my

(d) An educated woman

TASK 4 - PLAY
a) In the sitting room
b) Two scenes
c) The mother asked him in his activities after drawing the rocket.
d) He should keep his things back where they belong
e) Nervous, hasty, confused
f) Supportive, helpful, unity, caring, understanding
g) Ben learns how to handle his personal property

TASK 5: NOVELLA
(a) Arithmetic
(b) In the headmaster's office
(c) A lion
(d) He is very average and all other subjects won't help him. Arithmetic stood between him and the further knowledge that would help him to get everything.
(e) He liked other subjects more than arithmetic.
(f) It was very appropriate as he had to go over it, there wasn't a subject that could replace it.
(g) Firm and helpful. A strict teacher who sticks to his words/ promises.
(h) We have to work hard even where we feel we are not that good at other things

KISWAHILI

A.UFAHAMU
1. A. 6. D
2. A 7. D
3. A 8. D
4. B 9. B
5. C 10. B

B.UFUPISHO
1. Rosi na mti mkuu walishikana katika masomo yao. Walisaidiana bila kujali tofauti za gredi zao.
2. Rosi na Mti mkuu walifana katika masomo waliyokuwa hodari.
3. Licha ya watu kuwasema kwa ubaya ili kuwatenganisha, marafiki hawa waliwapuza na kuzingatia ndoto zao. Kwani walielewa kilichowaleta pamoja. Walikata kusikia kelele za chura hadi wakunywe maji
4. Marafiki hawa walifuzu, wakaajirwa, wakawajengea wazazi wao majimba kama shukrani kwao.

C.MTUNGO
1. D. 6. B
2. C 7. C
3. B 8. D
4. A 9. D
5. A 10. B

D. SARUFI NA LUGHA
1. B. 11. C 21. C
2. D 12. A 22. C
3. D 13. C 23. A
4. D 14. A 24. C
5. C 15. B 25. D
6. A 16. A
7. B 17. B
8. A 18. C
9. D 19. D
10. A 20. B

PAPER 2
-Umbo mwafaka la barua
-Utangulizi na nemi
-Maamkizi na kujuliana hali
-Habari fuji kuhusu hali yake mwandishi
-Muhtasari wa mambo gredi ya saba
-Matarajio katika gredi ya 9
-Orodha na maelezo mafupi kuhusu maandalizi
-Nasaha za kijumla
-Maagano

Msamiazi na matumizi ___/04
-Mwandishi ametua maneno yanayofaa katika uandishi wa barua ya kirafiki kulingana na kiwango chake,
-Mwandishi ameyapanga maneno kwa njia ifaayo akizingatia baadhi ya sharia za sarufi ya Kiswahili,
-Mwandishi ameyatumia maneno aliyoyateua kwa ufasaha na kuonyesha kiwango fulani cha ubunifu na ufundi,
-Mwandishi ametumia miundo mbalimbali ya sentensi kuonyesha makuzi na maendeleo yake katika lugha,
-Hoja za mwandishi zinabainika vyema katika kazi yake.

Mpango + Mindo _/03
-Mwandishi amepanga vipengee vya muundo kwa njia inayofaa,
-Vipenge vya barua ya kirafiki vinajitokeza waziwazi na vimeandikwa vifaavyo,
-Mwandishi amepanga aya zake kiwakati,
-Mwandishi ametoa maelezo ya hoja zake kwa ufasaha,
-Maudhui yaliyotarajiwa yamejitokeza waziwazi.

Jumla _/15

Sehemu ya B
Fasihi Simulizi (alama 10)
a) Eleza tofauti kuu baina ya hurafa na hekaya (alama 2)
> hurafa ni hadithi inayowahusu wanyama na hekaya ni hadithi za kubuni,
> hurafa humchukua mnyama kama mhusika mkuu na hekaya ni hadithi za kubuni,
> hurafa hueleza maisha ya jamii ya wanyama na hekaya husimulia visa vya kubuni,
> hurafa ni hadithi inayowajelea wanyama na hekaya ni hadithi inayoonyesha mhusika anayefaidi kwa ujanja wake.

b) Taja umuhimu wa hurafa na hekaya katika jamii. (alama 3)
> huburudisha hadhira
> huerevusha hadhira
> huonya, husuta au hutahadharisha jamii
> huendeleza itikadi teule za jamii kama umoja, ushirikiano, ujima, heshima
> huzindua jamii na kuieekezwa pafaapo

c) Taja vipengee vya kuzingatia wakati wa kuwasilisha hurafa au hekaya (alama 5)
> Kiwango cha lugha (lugha hutegemea hadhira)
> kiini cha hadithi (jambo linalozungumziwa katika hadithi)
> sauti ifaayo ya mtambaji (mawimbi katika sauti wakati wa kuwasilisha)
> ishara na vitendo (husisitiza jambo kwa ishara na vitendo)
> mpangilio mzuri wa matukio (vitushi vipangwe kwa mdiririko mzuri)

d) Taja mbinu za lugha zinazotumiwa katika kazi hii (alama 1)
> tashbihi
> taswira-jozi
> sittiari
> miserno ya nahau
> methali

Taja maudhui yoyote matatu yanayojitokeza. (alama 3)

- > malezi mema — babake Jasiri anaonekana mzazi aliyewajibika kumlea mwanawe hasa anaposema kuwa Mungu amempa mzigo wa kumwelekeza Jasiri.
- > Unyenyekevu — babake Jasiri anawaomba watakaokutana na Jasiri wamvumile na kumfundisha, anawashukuru wana habari — Jasiri anawashukuru wanahabari kwa kupeleka habari zao ulimwenguni
- > Umaskini — babake Jasiri ana wasilwasi ikiwa Jasiri ataweza kuwa mtu
- > Bidii anaonekana kuwa kijana mwenye bidii
- > Ushirikiano — Jasiri anashirikiana na wenzake katika shughuli zao za kilimo
- > Uwajibikaji — babake Jasiri anawashirikisha wahisani kuwapiga jeki vijana hawa
- > Tumaini na rajua — Jasiri anaonekana mwenye tumaini kuwa shughuli yao itainua viwango vya uchumi wa kijiji.
- > Uongozi na ushawishi — Jasiri anaonekana kuwa kiongozi na mwenye ushawishi kwa kuwaunganisha vijana.

b) Eleza sifa za wahusika hawa (alama 2)

i) Jasiri

- > Mpole
- > Mnyenyekevu
- > Msikivu
- > Mwadilifu
- > Mwenye bidii
- > Mwajibikaji
- > Mkulima

ii) Babake Jasiri

- > mwadilifu
- > mnyenyekevu
- > mizi mwema
- > mwajibikaji
- > mwenye bidii
- > mpenda masomo
- > mkulima
- > mshawishi

c) Mwandishi wa kazi hii alikuwa na dhamira gani? (alama 2)

- kuzindua jamii dhidi ya uzembe
- kuzindua jamii dhidi ya mapuza ya elimu
- kuonyesha kuwa bidii hulipa
- kuonesha umuhimu wa ushirikiano
- kuonesha kuwa vijana wakipewa nafasi wanaweza kufanya makubwa
- kuonesha thamani ya maadili
- kuonesha thamani ya elimu
- kuonesha kuwa mtoto akielekewa anaweza kufaulu

d) Taja tamathali rilizotumiwa katika kazi hii ya fasihi (alama 2)

- sitira - misemo ya nahau - methali

e) Eleza mandhari ya kazi hii. (alama 1)

- kijijini kwa kina Jasiri - nyumbani kwao Jasiri - shambani kwao Jasiri

Sehemu ya D Maswali:

a) Taja maudhul yanayoitokeza katika kazi hii. (alama 3)

- michezo ya watoto - dhima au umuhimu wa nyimbo
- uongozi — uongozi wa watoto katika nyimbo
- taasubi za kiume— Mabula anamtaka mkewe kumtii kwa nguvu
- msimamo dhabiti — mkewe Mabula ana msimamo dhidi ya kuelekeza watoto

b) Kwa mujibu wa mazungumzo haya, taja sifa za Mabula. (alama 2)

- mshika mila
- mwenye msimamo thabiti
- jasiri au mkakamavu
- mhafidhina (asiyependa mabadiliko)

c) Eleza dhamira ya mwandishi wa kazi hii. (alama 2)

> kuonyesha umuhimu wa mila - kuonyesha umuhimu wa michezo ya watoto - kuonyesha walivyo watu namilimemo - kuonesha taasubi za kiume

d) Taja mandhari ya onyesho hili. (alama 1)

> nyumbani au maskanini > kijijini

e) Bainisha mbinu za lugha alizotumia mwandishi katika onyesho hili. (alama 2)

- misemo ya nahau - methali

Sehemu ya E

Maswali

a) Lipe kichwa shairi hili (alama 1)

- mtoto umoja wetu.

b) Ujumbe mkuu katika shairi hili ni upi? (alama 1)

- mtoto ni mali ya jamii
- mtoto ni wa kila mtu
- kila mtu awajibike kumlea mtoto
- mtoto apewe haki yake
- haki za mtoto

c) Taja mbinu mbili za lugha zilizotumika katika shairi. (alama 1)

- tashibhi

- taswira jozi

- methali

d) Mwandishi ana maoni yapi ubeti wa pili? (alama 1)

- mtoto anapozaliwa asiachiwe mmoja kumlea bali sote tuwajibike hata kumkosoa anapokosa.
- e) Onyesha jinsi mshairi alivyotumia uhuru wake kwenye shairi. (alama 1)

kufupisha maneno — walokuja (waliokuja)

kurefusha maneno— tumfaye (tumfaye)

kuboronga sarufi—kila haki kutendea

(kutendea kila haki)

INTEGRATED SCIENCE

1. C	7. C	13. C	19. B	25. C
2. A	8. B	14. D	20. C	26. C
3. C	9. A	15. B	21. C	27. B
4. B	10. D	16. C	22. A	28. C
5. C	11. C	17. B	23. D	29. D
6. C	12. A	18. D	24. A	30. B

SECTION B

31. No definite volume.

No definite shape.

-Have lower density than solids and liquids.

32. a. Boiling tube

b. Retort stands and clamp

c. Gas jar

33. -makes construction materials

-makes stainless steel tools

-used to make manufacturing tools

34. a. Anhydrous cobalt (ii) chloride+water

b. Temporary chemical change

35. Acids-making fertilizers.

-hydrochloric acids produced on the stomach kills germs present in food.

Bases-make anti-acid medicines

-used to make detergents

36. - oviduct

- vagina

-cervix

37. produce female sex cell

38. water, excess salts and urea

39. cool the body/regulate body temperature.

protect the body from ultra-violet

40. a) - proteinuria

- kidney stones

-kidney failure

b) - keeping hydrated always

- avoid too much animal protein

-exercising regularly

41. Rubbing and induction

42. Protons and neutrons

43. B

-shoe B exerts little pressure which prevents it from sinking in

44. a. Bar magnet

b. Horse shoe

45.- used in preservation of soft drinks

- used in making medals e.g. gold, silver

- are sources of food nutrients

AGRICULTURE & NUTRITION

1. B	11. B	21. C
2. D	12. C	22. B
3. C	13. D	23. C
4. B	14. B	24. C
5. A	15. C	25. B
6. C	16. B	26. C
7. B	17. B	27. B
8. D	18. D	28. B
9. C	19. C	29. D
10. D	20. B	30. B

SECTION B

- > 31. practicing strip cropping
- > Constructing stone lines
- > Constructing bunds
- > Constructing trash lines
- > Constructing grassed waterways

32. Soil conservation is a combination of farming practices to protect soil from degradation, (reduce eroding of soil and eliminate soil pollutants)

33. Strip cropping

- > 34. Curled leaves
- > Punctured leaves
- > Cut-off seedlings

35. These are practices carried out after harvesting crops to preserve the quality and prolong the shelf life of harvested crops.

36. Cleaning -Drying -Sorting -Grading -Packing

37. Beheading

- > Defeathering
- > Singeing
- > Washing
- > Poultice fold

39. -Regularly moving the fold to a new site

-Keep the fold in a safe place

-Providing birds with clean water

-Maintain hygiene in the fold

-Shelter the fold from rain to avoid wetness

40. A seam is any part of a garment where two or more pieces of fabric are joined together using permanent stitches

- 41. Plain seam
- > Open seam
- > Overlaid seam
- > Double stitched seam
- > French seam
- > Run and fell seam

42. Firmly stitched

- > Accurately stitched
- > Neatly stitched
- > Appropriate width
- > Properly matched
- > Well-pressed and flat

43. -Dusting

- > Wiping
- > Scrubbing
- > Vacuum cleaning
- > Mopping

44. Scaling

- > Guling
- > Cleaning
- > Salting
- > Deep frying

SOCIAL STUDIES

SECTION A

1. D 11. B
2. B 12. A
3. A 13. D
4. C 14. B
5. B 15. A
6. A 16. A
7. B 17. D
8. C 18. C
9. D 19. C
10. C 20. B

A) Evolution:- Is the gradual and continuous change in living organism mainly from simple to complex form.

B) Changes that took place

- Arms and hands became shorter.
- The skull was enlarged
- Jaws and teeth became smaller
- Hair reduced on the body
- Brain capacity became bigger.

A) Olduvai Gorge in Tanzania

- Hadar in Ethiopia
- Taung in Botswana
- Fort Ternan in Kenya
- Zambia

B) Africa as a cradle of mankind (Reasons)

- Africa is centrally located
- Oldest fossils were discovered in Africa's archaeological sites
- Good climate
- Availability of water from lakes and rivers.
- Suitable hunting grounds

3. A)- Led to modern writing and arithmetics

- Led to improvement of medicine
- Led to development of modern transport
- Led to improved farming and agriculture techniques
- Has led to the development of technology

B) Factors that led to Swahili culture.

- Deep natural harbours.
- Good climate and fertile soils
- Islamic religion.
- Migration and settlement.
- Development of the Indian Ocean trade.

4.A) Factors for population increase.

- Better medical facilities
- Cultural preferences
- Early marriages.
- Low mortality rates.
- Polygamy in families.

B.) Increased population may lead to the following:

- Increased pollution
- Congestion
- Unemployment
- Conflicts and war.
- Environmental degradation
- Increased innovation.
- Increased human capital

4. C) Types of migration

- Rural to urban migration.
- Urban to urban migration
- Urban to rural migration.
- Rural to rural migration
- Immigration
- Emigration

5 A) Weather is the state of the atmosphere of a place for short period of time.

Climate is the weather patterns of a place recorded or observed for a long period of time, usually 35 years.

8) Altitude

Latitude

Distance from large water bodies

Relief.

Influence of wind and air masses

c) X - Dessert climatic region

D) Characteristics of desert climatic region

Cloudless skies

Very cold nights and very hot days.

Annual rainfall is below 250mm

Hot and dry throughout the year.

6 A) Meaning of career path.

A career path is a route you take to achieve your career goals

B) Factors to consider.

Skill

Talent

Abilities.

(c) - Mathematics, languages, computer, Integrated science

7. A.) A Support system

A pre-career support system is a network of people who can offer advice, feedback and assistance in a professional department.

B.) Makes one motivated.

Stays focused

Remains resilient.

8. a) Self esteem: How we value and perceive ourselves.

- Negative self-talk
- Construct Comparison to others
- Experiences of bullying
- Rejection

Capacity to be aware of, control of one's emotion and handle to interpersonal relations

Mindfulness -Practice of being aware of own emotions

Journalising -writing down your thoughts and feelings

10

- I. Critical thinking and problem solving
- II. Skills in technology.

11. Right to health care

- Right to shelter
- Right to Food
- Right to clothing
- Right to inheritance
- Right to leisure/play
- Right to education

PRE-TECHNICAL STUDIES

SECTION A

1. B 7. D 13. B 19. C
2. A 8. A 14. C 20. B
3. C 9. C 15. C
4. B 10. D 16. B
5. B 11. B 17. B
6. A 12. D 18. D

SECTION B

1. -Concentric circles:
These circles share the center point but have different radii.

-Tangent circles: These circles intersect at exactly one point.

2. a. pipe cutter used to cut pipes and tubes
b. scrapers used primarily focused on removing or scraping away material.
c. secateurs' used to prune flowers and small branches from plants.
d. snip are hand tools used for cutting various materials, primarily sheet metal and other thin materials.

3. a. Foundation for technical and vocational education and training (TVET)
b. Career progression pathway
c. Development of essential life skills.

4. I) Technical drawing -is used where measurements and accuracy is required in designs. Engineering drawings, architectural plans, technical diagrams, schematics.

II) Artistic drawing -used for drawing that depicts personal expressions. Portraits, landscapes, abstract art, sketches

5. i) MakeCode, Scratch
- ii) Code.org
- iii) Sprite box,
- iv) Microsoft Visual Studio
- v) Roblox
- vi) Minecraft

6. Classification according to size

- i) super computers
- ii) mainframe computers
- iii) mini computers
- iv) micro computers

Classification according to purpose

- i) general purpose computers
- ii) classification by functionality

Classification according to functionality

- i) digital computers
- ii) hybrid computers
- iii) analogue computers

Items	Goods	Services
Teaching		Teaching
Furniture	Furniture	
Security		Security
Food	Food	

8. i) Total cost of construction (project cost)
 - ii) Financing options
 - iii) Ongoing costs (cost effectiveness)
9. i) Clear and concise communication
- ii) Active listening and feedback
- iii) Regular and consistent communication

CREATIVE ARTS & SPORTS

1. D 9. D 17. D 25. A 33. B
2. A 10. B 18. A 26. C 34. C
3. B 11. C 19. B 27. D 35. C
4. D 12. B 20. A 28. D 36. B
5. B 13. C 21. B 29. A 37. B
6. B 14. D 22. A 30. D 38. B
7. C 15. D 23. D 31. B 39. B
8. B 16. A 24. A 32. C 40. A

41. Rhythm, melody, harmony

42. putting a dot

tieing the note

43. Character, plot, setting, language

44. prop- to enhance movements
-symbolize certain aspects of performance. examples: ribbons

45. -American grip

-the v-grip

-the finish grip

46. Dodging, marking

47 Power, reaction time

48. Pivoting- turning with one foot on the ground while the other foot makes repeated short steps

49. -drawing

-painting

-sculpture

- montage

- collage

50 Teacher, painter, graphic designer, art teacher, illustrator, painter, architect

51. red, yellow, orange, purple

52. man-made-nylon, polythene, plastic
natural- sisal, reeds, raffia, banana fibre

C.R.E

- | | | |
|------|-------|-------|
| 1. C | 7. C | 13. B |
| 2. B | 8. A | 14. B |
| 3. A | 9. D | 15. A |
| 4. B | 10. D | |
| 5. D | 11. A | |
| 6. A | 12. D | |

16. Ways in which CRE helps us to relate well with others.

- ◆ We acquire values like respect to ourselves and even unto others.
- ◆ It makes us to make correct moral decisions esp. before making decisions that affect our moral well-being.
- ◆ We love others just as God instructed us to love others because love is the greatest gift.
- ◆ CRE makes us patient enough to listen to others especially those who require our help.

17. Difference between first and second account of creation

- ◆ In the first account man was created last while in the second account he was created first.
- ◆ The first account mentions the creation of light, moon, stars and the sun plus creeping things and fish, these are not mentioned in the second account.
- ◆ The first account records how God worked for the first six days and rested on the seventh day which is Sabbath day, this is not mentioned in the second account.
- ◆ The second account mentions planting of the garden of Eden but in first account there is no mentioning of the garden of Eden.
- ◆ In the first account marriage is for procreation while in the second account it is for companionship.
- ◆ In the first account, man and woman were created the same day while in second account man was created first then when he slept God took one of his ribs and formed a woman.

18. Ways by which the bible can be used for holistic growth of a person.

- ◆ Intellectual growth- reading the bible gives us knowledge and wisdom about the various events that happened long ago, how to solve problems etc.
- ◆ Spiritual growth- reading the bible, praying and interceding and even meditating makes us grow spiritually.
- ◆ Physical growth- when we read the bible we learn that God created us in his own image, so physically, we are not very different from God.
- ◆ Emotional growth- The bible teaches us how to love and avoid negative emotions like: anger, envy, and jealousy.

19. Social changes that occur in both boys and girls during adolescence.

- ◆ Attraction to social media like Facebook.
- ◆ Developing friendship with their peers.
- ◆ Developing attraction to opposite sex.
- ◆ Spending a lot of time with peers that their families.

20. Dangers of chatting with strangers:

- ◆ Stealing from parents to buy data bundles.
- ◆ Joining unlawful groups like that of terrorism.
- ◆ Being involved in acts of danger like: rape, kidnapping or being killed.
- ◆ Visiting inappropriate sites
- ◆ Introduction to drugs and substance abuse
- ◆ Dropping out of school.

21. Consequences of sin to man:

- ◆ Led to enmity between snake and man.
- ◆ Man became prone to sin.
- ◆ Human beings started killing each other.
- ◆ The perfect relationship between God and man was broken.
- ◆ Women started experiencing pain during child bearing.
- ◆ The ground was cursed, was to toil in order to eat.

◆ Man was chased out of the Garden of Eden.

22. Examples of ungodly covenants:

- ◆ Agreements between drug dealers.
- ◆ Agreements between robbers.
- ◆ Agreements between devil worshippers.
- ◆ Agreements between criminals.

23. Miracle of healing of blind Bartimaeus. (Mat 7:11-11,90 1918410, M 12:17-19)

- ◆ They came to Jericho, as Jesus, his disciples and a large crowd was leaving, 4 M. beggar named Bartimaeus son of Timaeus was sitting by the road.
- ◆ When he heard that Jesus of Nazareth was passing, he shouted asking... f...01, on him.
- ◆ Many of the people scolded him and ordered him to keep quiet but she shout...t., more.
- ◆ Jesus stopped and ordered him to be called.
- ◆ When he went where Jesus was, Jesus asked him what he wanted him to do, for him
- ◆ Bartimaeus told him that he wanted to see again.
- ◆ Jesus told him to go because his faith had made him well.
- ◆ At once he was able to see and followed Jesus on the road.

24. Ways one can involve God in his/ her challenges:

- ◆ Reading the bible for guidance or help.
- ◆ Having faith by trusting that whatever you are hoping for will succeed.
- ◆ Praying to God.
- ◆ Church activities that one can engage in to promote responsibility.
- ◆ Door to door ministry of evangelism.
- ◆ Helping those in need.
- ◆ Contributing to church projects and programs.
- ◆ Visiting the sick and the needy and encouraging them/ praying for them.
- ◆ Interceding for others.
- ◆ Providing financial support to less fortunate.
- ◆ Participating in community services like cleaning to maintain hygiene.

26. Ways in which Christians can help the needy in the society.

- ◆ Educating them to better their future.
- ◆ Offering financial support to them.
- ◆ Starting for them some income generating projects.
- ◆ Supporting some institutions that help them like children homes.

27. Ways of overcoming peer influence:

- ◆ Praying.
- ◆ Being principled in our decisions.
- ◆ Avoid idleness.
- ◆ Stick to the rules and regulations that are available.
- ◆ Proper choice of friends.

28. Consequences of engaging in irresponsible sexual behaviour.

- ◆ Dropping out of learning institutions like schools.
- ◆ Poor educational performance.
- ◆ Early marriages.
- ◆ Guilt and shame.
- ◆ Early pregnancy.
- ◆ Low self esteem.

29. Ways of discovering ones, talents, gifts and abilities

- ◆ Praying to God- he will reveal our gifts or talents.
- ◆ Taking part in what we enjoy doing most, we shall discover our talents or gifts.
- ◆ Engaging in some problem solving experiences.
- ◆ Others can observe when we are taking part in different tasks and tell us about our abilities/ gifts or talents.

30. Reasons that can make one misuse time:

- ◆ Lack of role model to guide us on proper time management.
- ◆ Idleness.
- ◆ When one is frustrated.
- ◆ Having a lot of freedom.
- ◆ Having a lot of money with no proper spending model.
- ◆ Negative peer influence.

I.R.E

- | | | |
|------|-------|-------|
| 1. B | 7. C | 12. B |
| 2. C | 8. B | 13. C |
| 3. A | 9. A | 14. D |
| 4. D | 10. D | 15. A |
| 5. B | 11. B | |

SECTION B

16. 1. The poor (Al-fuqara)
2. The needy (Al-masaakin)
3. Zakat collectors (Al-aamilin)
4. Slaves/captives (Al-riqaa)
5. Debtors (Al-gharimin)
6. The new converts (Al-mualafatul qulub)
7. The welfare/stranded travelers (Ibn sabil)
8. In the cause of Allah (Filsabil-lah)

Any 5 x 1 (5 Marks)

17. Legitimate ways of spending income

- i. For Allah's sake/ Acts of Ibada such as Zakat, Sadaqa
- ii. For family and self
- iii. Assisting other members of the family

3 X 1 (3 Marks)

18. Rites of Hajj

- i. Putting on Ihram
- ii. Performing Tawaf/going round the Kaaba
- iii. Performing Saayi (walking between two hills safe and marwa)
- iv. Standing at the plains of Arafat
- v. Performing Ramyl (throwing of pebbles/stoning)
- vi. Shaving or trimming the hair.

Any 5 x 1 (5 Marks)

19. Teachings from Suratul Luqman verses 12-19

- i. Shirk is the biggest sin
- ii. Performance of prayers is required
- iii. Enjoining good and forbidding evil
- iv. Allah swf has the right to be worshipped
- v. Mothers go through extra hardship in pregnancy and parenthood.
- vi. Obedience to parents is required.
- vii. Allah (SWT) knows everything.

Any 5 x 1 (5 marks)

20. Causes of deviant sexual behaviour

- i. Absentee parents
- ii. lust and desire for experimentation
- iii. Irresponsible parents or relatives
- iv. use of drugs
- v. lack of religious awareness
- vi. peer influence
- vii. exposure to pornographic pictures
- viii. Indecent dressing according to Islam
- ix. poverty.

Any 3 x 1 (3 marks)

21. Causes of conflicts in marriage

- i. Lack of Taqwa
- ii. Breakdown in communication
- iii. Failure to provide basic needs
- iv. Lack of patience and forgiveness
- v. Unfaithfulness
- vi. Lack of respect and appreciation
- vii. Unrealistic expectations
- viii. Use of drugs

Any 5 x 1 (5 marks)

22. Importance of hadith

It is the second source of Islamic sharia
It helps to understand the Quran
It guides muslims on various acts of worship
It helps muslims to learn virtues and moral principles
It helps muslims to know more about the life of the Prophet (SAW).

Any 4 x 1 (4 marks)

23. Types of Saum

Faradh Saum -this is obligatory or compulsory fast observed during the month or Ramadhan.
Sunna Saum -These are optional fasts recommended by the prophet (SAW) eg. fasting on Mondays and Thursdays in a week.

Nadhir fast. This is a fast observed upon one taking a vow and has been made.
Kafara fast -this is a fast observed to make up for a sin committed
Qadha fast -this is the fast observed to compensate for the first fast missed due to valid reasons.

Any 5 x 1 (5 marks)

24. Socio religious conditions during pre-Islamic Arabia (Jahiliyah period)

Pre-Islamic Arabia -is known as the Jahliya period (period of ignorance)
This is the period before the preaching of Islam by prophet Muhammad(SAW)

- ✓ socio-religious conditions
- ✓ Arabs were worshipping idols
- ✓ There was killing of infant baby girls
- ✓ There was adultery and fornication
- ✓ Drinking of alcohol
- ✓ Misuse or mistreating of women
- ✓ The weak people or orphans were denied this rights
- ✓ There was several civil wars between different clans

Any 5 x 1 (5 marks)