

Name Index No.....
 School Adm No
 Stream Candidates Signature.....

233/1

MARKING SCHEME**CHEMISTRY (Theory)****Paper 1****March – 2025 – 2 hours**

**FORM FOUR CHEMISTRY JOINT EXAM
 KENYA CERTIFICATE OF SECONDARY EDUCATION**

Instructions to candidates

- (a) Write your name and index number in the spaces provided above.
 (b) Sign and write the date of examination in the spaces provided above.
 (c) Answer **all** the questions in the spaces provided in the question paper.
 (d) **Non-programmable** silent-electronic calculators and KNEC mathematical tables may be used.
 (e) All working **must** be clearly shown where necessary.
 (f) **This paper consists of 18 printed pages.**
 (g) Candidates should check the question paper to ascertain that all the pages are printed as indicated and that no question are missing.
 (h) Candidates should answer the question in English.

For Examiner's Use Only

QUESTIONS	MARKS OUT OF 80
1 – 27	

Chem 233/1 Joint Exams – March 2025

1. Elements X and Y have atomic numbers of 12 and 16, respectively. Using dots (.) and crosses (x), show how bonding takes place. (3mks)

Electron distribution = 1 mole
 Charge = 1 mole
 X: 12
 Y: 16
 EC = 2.8.2
 Y²⁺: 2.8
 Y²⁻: 2.8.8

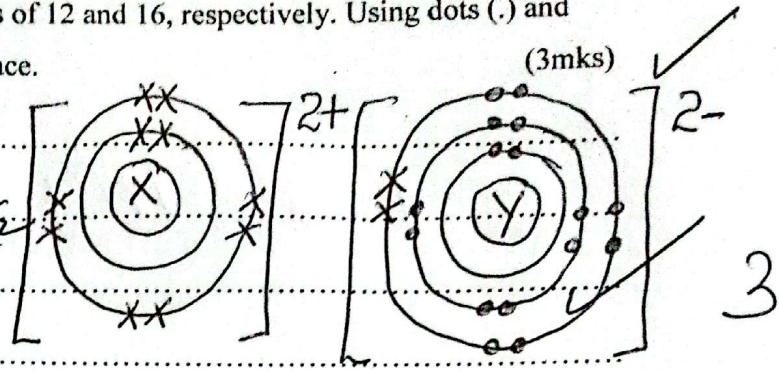

2. The table below shows elements of group X and group Y of the periodic table. The elements follow each other down the group as in the given order. Group X have a valency of 2.

Group X			Group Y			
Element	P	Q	R	K	L	M
Atomic radius (nm)	14.0	19.5	19.7	5.2	7.9	18.2
Ionic radius (nm)	8.6	11.5	12.4	12.7	16.00	19.4

a) The atomic radii of elements in group Y are smaller than the corresponding ionic radii for each element. Explain (1mk)

They form ions by gaining electrons leading to electron-electron repulsion

b) State the general name given to elements in group X. (1mk)

Alkaline earth metals

c) Give the formula of the compound that would be formed between Q and L (1mk)

Q₂L

3. The graph below shows the behaviour of a fixed mass of a gas at constant temperature.

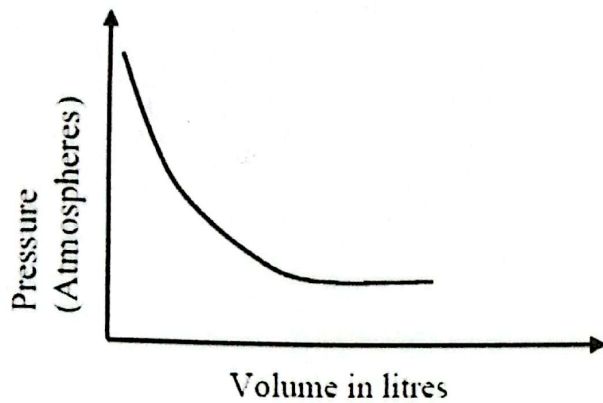

- a) What is the relationship between the volume and the pressure of the gas? (1mk)

At constant temperature Volume is
inversely proportional to pressure 1

- b) 3 litres of oxygen gas at one atmosphere pressure were compressed to two atmospheres at constant temperature. Calculate the volume occupied by the oxygen gas. (2mks)

$$P_1 V_1 = P_2 V_2 \quad \checkmark \frac{1}{2}$$

$$1 \times 3 = 2 \times V_2 \quad \checkmark$$

$$\frac{1 \times 3}{2} = V_2$$

$$1.5 \text{ litre} = V_2 \quad \checkmark \frac{1}{2}$$

4. The table below shows some properties of substances A, B and C. Study it and answer the questions that follow.

Substance	Melting point $^{\circ}\text{C}$	Solubility in water	Electrical conductivity	
			Solid state	Molten state
A	659	Insoluble	Good	Good
B	1620	Insoluble	Poor	Poor
C	803	Soluble	Poor	Good

Select substance

- I. With a metallic structure.

(1mk)

A ✓

..... 1

- II. Is not likely to be an element. Give a reason.

(2mks)

= C ✓

= Ionic substances formed when a
metal react with a non-metal ✓ 2

—————
 3

5. The diagram below is an energy level graph for reactants and products during a chemical reaction.

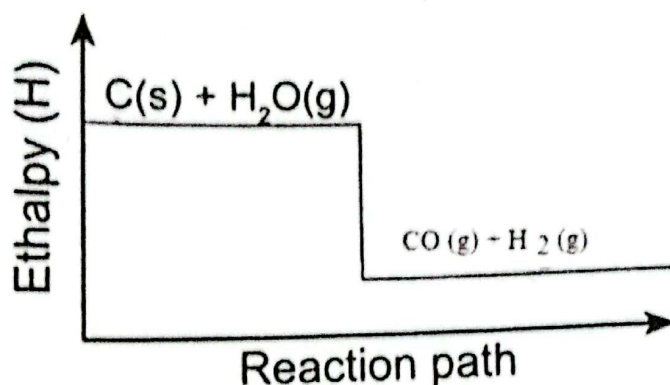

- a) What would be the effect on the position of equilibrium if temperature is increased?

Explain.

- The equilibrium would shift to the left ^(1 1/2 mk) ✓
 - Since the forward reaction is exothermic ✓

- b) How would a decrease in pressure affect the amount of hydrogen gas? ^(1 1/2 mk) ✓

- Amount of hydrogen would increase ✓
 - Decrease in pressure shifts the reaction to the side with more molecules ✓

6. Study the reaction scheme below and answer the question that follow

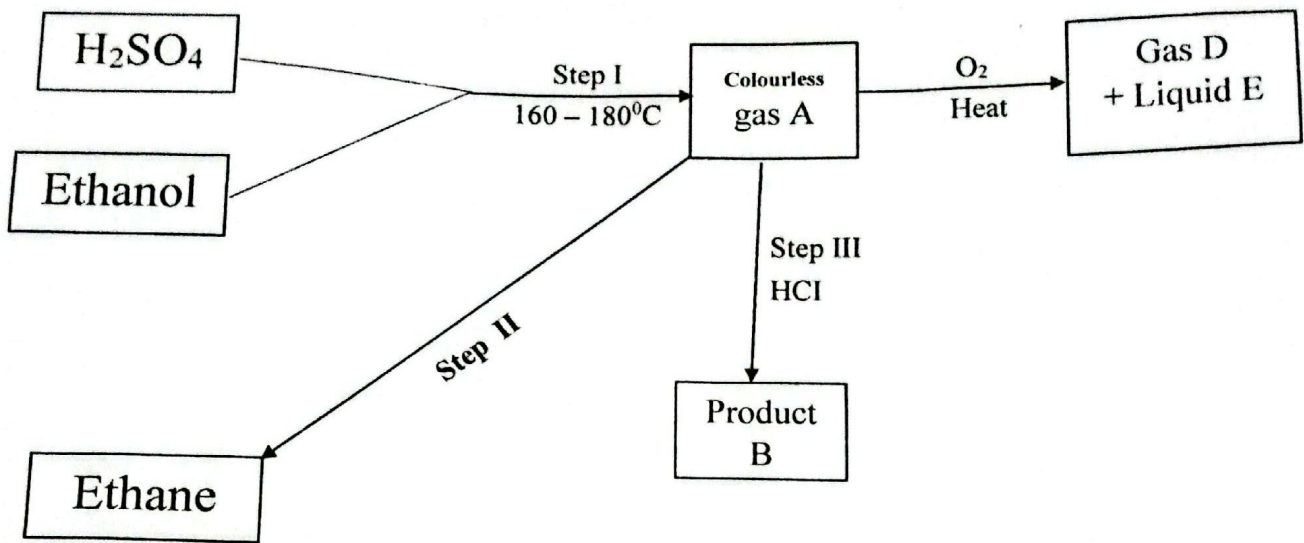

a) Name;

I. Product B: Chloroethane ✓₂ (1/2mk)

II. Liquid E: Water ✓₂ (1/2mk) ①

b) Name the type of reactions taking place in step I and II

I. Step I: Dehydration ✓₂ (1/2mk)

II. Step II: Addition reaction ✓₄ (1/2mk) ①
Addition of Hydrogen

c) State the importance of the reaction taking place in Step II (1mk)

..... Hardening of oils ✓ ①

Chem 233/1 Joint Exams – March 2025

3

7. Urea, $(\text{NH}_2)_2\text{CO}$, is prepared by the reaction between ammonia and carbon (IV) oxide.
- $$2\text{NH}_3(\text{g}) + \text{CO}_2(\text{g}) \longrightarrow (\text{NH}_2)_2\text{CO}_{\text{aq}} + \text{H}_2\text{O}(\text{l})$$

In one process, 680kg of ammonia were reacted with excess carbon (IV) oxide. Calculate the mass of urea that was formed. (H=1.0, C=12.0, N=14.0, O=16.0 and R.M.M of ammonia = 17) (3mks)

$34 \text{ g ammonia} = 60 \text{ g of Urea}$
 $680,000 \text{ g ammonia} = \frac{680,000 \times 60}{34}$
 $= 1,200,000 \text{ g of Urea}$
 $\text{or } 1,200 \text{ kg Urea}$

(3)

8. The diagram below represents part of a set up used to prepare and collect gas N.

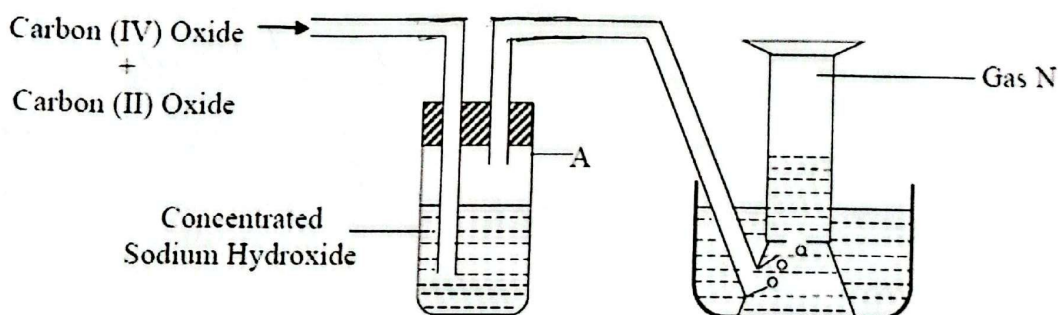

- a) Name two reagents that are reacted to produce both Carbon (IV) oxide and Carbon (II) oxide. (1mk)

Ethanedioic acid (oxalic acid) & concentrated sulphuric acid
 (1)

- b) Write the equation for the reaction which takes place in tube A. (1mk)

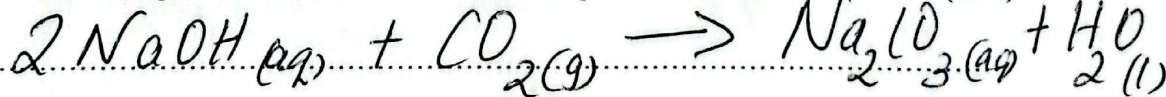

- e) State the observation made when Gas N reacts with hot Copper (II) oxide. (1mk)

Black, copper (II) oxide changes to brown ✓ (1)

9. The diagram below shows a set-up which was used by a student to investigate the effect of electricity on molten Lead (II) Iodide.

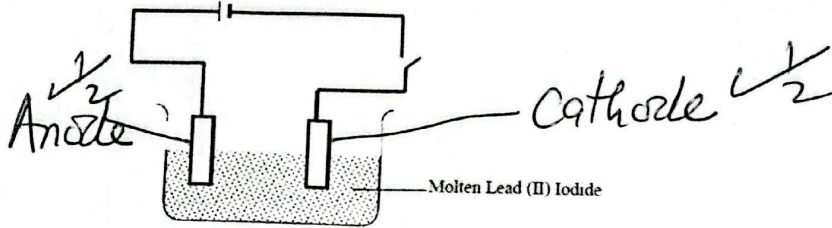

- I. Define the term electrolysis

(1mk)

The process of decomposing an electrolyte by passing an electric current through it ✓ (1)

- II. Indicate the anode and cathode

(1mk)

on the diagram

- III. Write the equation of the reaction at anode

(1mk)

$2I^- \rightarrow I_2 + 2e^-$ ✓ (1)

Chem 233/1 Joint Exams – March 2025

4

10. The table below gives some properties of gases X and Y.

Gas	Density	Effects of $\text{H}_2\text{SO}_4(\text{aq})$	Effects of $\text{NaOH}(\text{aq})$
X	Lighter than air	Reacts to form a salt	Dissolves without reacting
Y	Heavier than air	Not affected	Not affected

a) Describe how you obtain a sample of Y from a mixture of gases X and Y. (2mks)

- Pass the mixture of gases X and Y through H_2SO_4 solution. Gas X dissolves
 - Collect the remaining gas by downward delivery

b) Suggest a possible identity of gas X. Give a reason for your answer. (1mk)

- Ammonia
 - Reacts with sulphuric acid (drying agent) to form a complex salt

11. A white solid M was heated. It produced a brown gas A and a colourless gas. The residue left was yellow after cooling.

I. Name gases A and B. (2mks)

A Nitrogen (iv) oxide // NO_2 accept any
 B Oxygen // O_2

II. Write a balanced chemical equation for the decomposition of solid M (1mk)

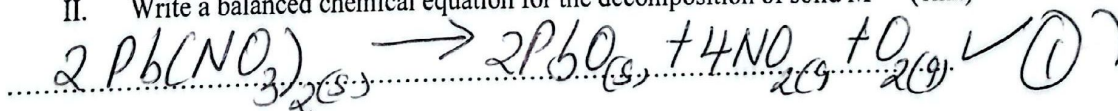

12. Aqueous ammonia solution is added to a colourless solution Y. A white precipitate which dissolves in excess ammonia to form a colourless solution P.

a) Identify;

(1mk)

I. The Cation present

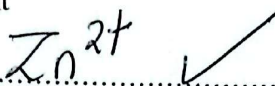

①

II. The white precipitate

(1mk)

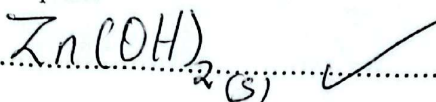

①

b) Write an equation for the formation of the complex ion.

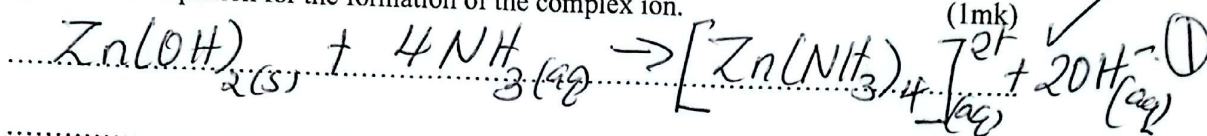

13. Below are pH values of some solutions.

Solution	Z	Y	X	W
pH	6.5	13.5	2.2	7.2

Which solution is likely to be

I. Acidic rain

Z ✓

(1mk)

①

II. Potassium hydroxide

Y ✓

(1mk)

①

Chem 233/1 Joint Exams – March 2025

⑤

III. Substance V reacted with both solutions Y and X. What is the nature of V.

(1mk)

Amphoteric ✓

①

14. When 0.6g of element M was completely burned in oxygen, all the heat evolved was used to heat 500cm³ of water, the temperature of the water rose from 23.0°C to 32°C. Calculate the Relative Atomic Mass of element M given that the specific heat capacity of water is 4.2Jg⁻¹ K⁻¹, density of water is 1.0gcm⁻³ and molar heat of combustion of M is 380KJ/mol.

(3mks)

$$\begin{aligned} \text{Heat change} &= \frac{500 \times 4.2 \times 9}{1000} \checkmark \\ &= 18.9 \text{ kJ} \\ 380 \text{ kJ} &\Rightarrow 1 \text{ M} \checkmark \\ \therefore 18.9 &\Rightarrow \frac{18.9 \times 1}{380} = 0.0497 \text{ mole} \end{aligned}$$

$$\begin{aligned} 0.0497 \text{ mole} &\Rightarrow 0.6 \text{ g} \\ 1 \text{ M} &= \frac{1 \times 0.6}{0.0497} \checkmark \\ &= 12.0 \checkmark \end{aligned}$$

③

15. Naturally occurring magnesium consists of three isotopes: 78.6% ²⁴Mg, 10% ²⁵Mg and ²⁶Mg. Calculate to one decimal place, the relative atomic mass of magnesium. (3mks)

$$\begin{aligned} \% \text{ of } ^{25}\text{Mg} &= 100 - 78.6 - 10 \\ &= 11.4 \checkmark \\ \text{R.A.M} &= \frac{(78.6 \times 24) + (10 \times 25) + (11.4 \times 26)}{100} \checkmark \\ &= \frac{2432.8}{100} = 24.328 \checkmark \end{aligned}$$

③

Chem 233/1 Joint Exams – March 2025

⑦

16. Describe how a solid sample of copper (II) carbonate can be prepared starting with copper metal. (3mks)

- Heat the Cu metal in air to obtain CuO ✓₂
- Add excess CuO to dilute HNO₃ / H₂SO₄ / HCl
- Filter to obtain the filtrate; To the filtrate add aqueous Na₂CO₃ / K₂CO₃ to ppt CuCO₃
- Filter to obtain CuCO₃ as a residue. Wash the residue with distilled water and dry between filter papers

3

17. Solid A forms a mixture with liquid B. State two properties of substance A that would make decantation the method of choice for separating the mixture. (2mks)

- Insoluble ✓
- Denser ✓

2

18. The structure of ethanoic acid

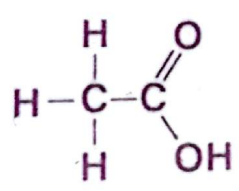

a) State the number of electrons used in bonding in a molecule of ethanoic acid. (1mk)

7 x 2 = 14 electrons ✓

1

6

b) Give the name of the following organic compounds.

(2mks)

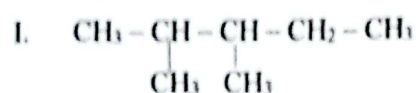

2,3 - dimethylpentane ✓ (1)

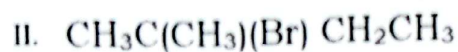

2 - bromo - 2 - methylbutane ✓ (1)

19. Hydrogen and bromine react according to the equation.

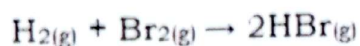

Use the bond energies given below to calculate the heat of formation of hydrogen bromide

Bond	Energy (KJ/mol)
H - H	436
Br - Br	192
H - Br	368

(3mks)

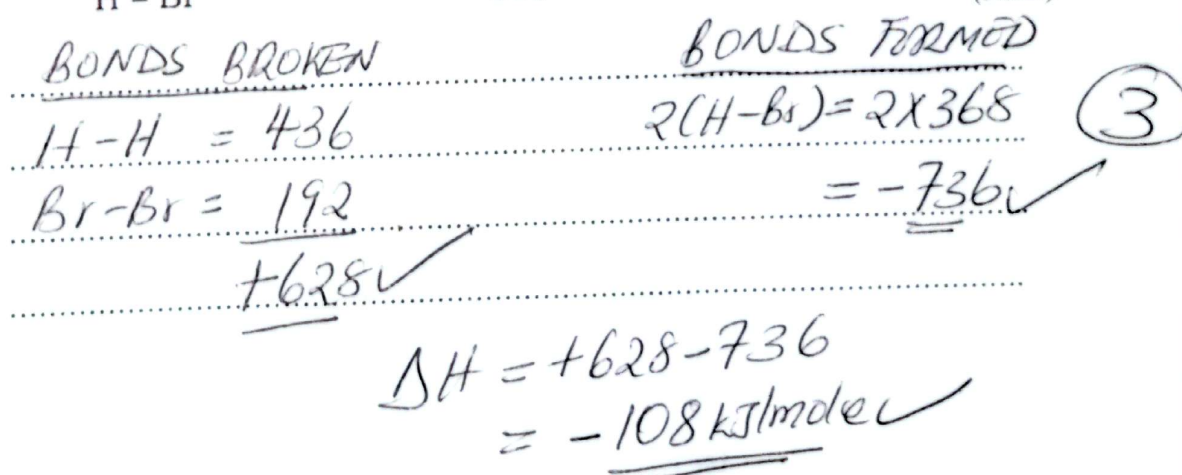

Chem 233/1 Joint Exams - March 2025

(5)

20. When sulphur is heated in a boiling tube in the absence of air, the yellow crystals melts into a golden yellow mobile liquid at 113°C . The liquid changes at 180°C into a dark brown liquid that is very viscous. Heating at 400°C produces a brown less viscous liquid.

a) Draw the molecular structure of sulphur in the yellow liquid. (1mk)

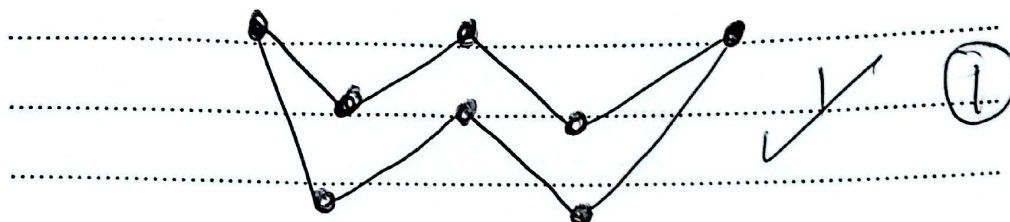

b) Name the allotropes of sulphur (2mks)

Rhomibic ✓
Monoclinic ✓

②

21. A hydro carbon contains 80% Carbon, and its Relative Molecular Mass is 30. Calculate its molecular formula ($\text{C}=12, \text{H}=1$) (3mks)

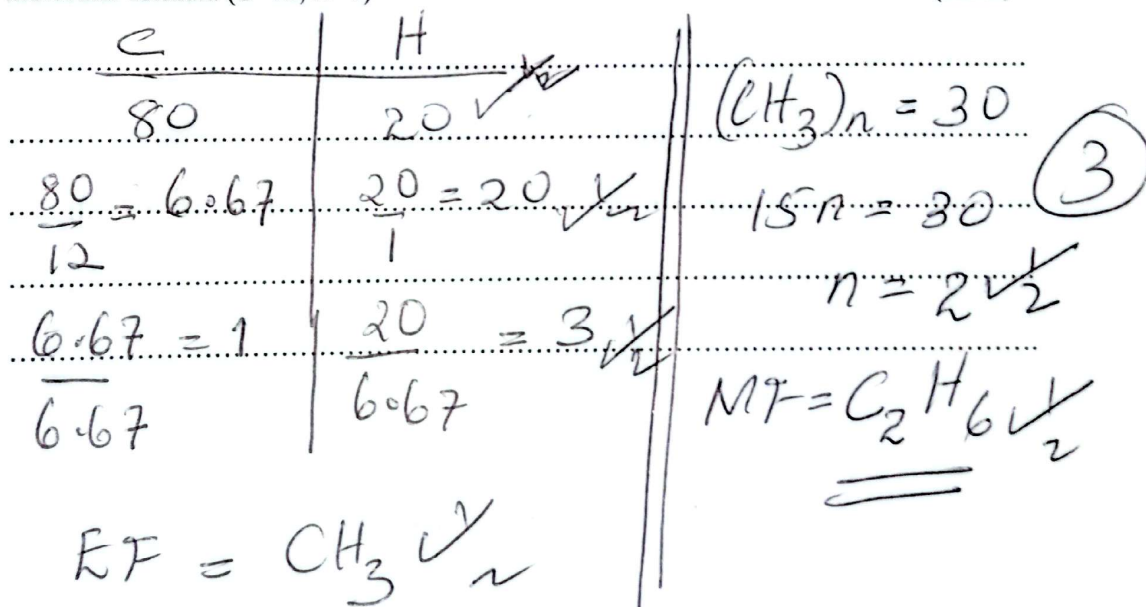

Chem 233/1 Joint Exams – March 2025

⑥

22. Describe a chemical test that can be used to distinguish between aqueous solutions of sodium carbonate and sodium hydrogen carbonate. (3mks)

To two separate test-tubes add dilute hydrochloric acid to both solutions. Sodium carbonate reacts vigorously producing rapid effervescence & white NaHCO_3 reacts more slowly with fewer bubbles.

23. For each of the following experiments, give the observations and the type of change that occurs (temporary physical or temporary chemical).

Experiment	Observation	Type of change
A few drops of water are added to small amount of anhydrous copper (ii) sulphate	Anhydrous CuSO_4 changes from white to blue	Temporary Chemical Change
A few crystals of iodine are heated gently in a test tube	purple vapour	Temporary physical

24. The set-up below shows the catalytic oxidation of ammonia in the laboratory.

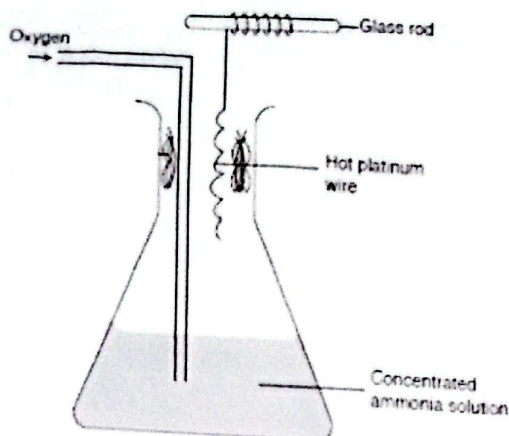

(a) State and explain the observation made.

= Hot platinum wire glows ✓
 * Reaction between ammonia and oxygen on the surface of platinum is exothermic ✓
 = Brown fumes are produced ✓
 * NO is further oxidised to NO_2 ✓ (2)

(b) Write a chemical equation for the first reaction taking place in the conical flask. (1mk)

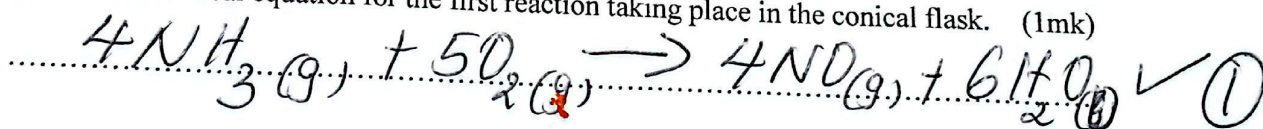

25.(a) Define the term solubility

solubility of a substance is the maximum mass of the substance that will dissolve in 100g of water (solvent) at a particular temperature ✓ (1mk)

(b) In an experiment to determine the solubility of solid Q in water at 50°C, the following data was obtained.

Mass of empty evaporating dish	=	46.5 g
Mass of evaporating dish + saturated solution	=	62.5 g
Mass of evaporating dish + dry solid Q	=	50.4 g

(2mks)

Use the data to calculate the solubility of solid Q.

$$\begin{aligned}
 \text{Mass of dry solid} &= 50.4 - 46.5 \\
 &= 3.9 \text{ g} \checkmark \\
 \text{Mass of saturated solution} &= 62.5 - 46.5 \\
 &= 16 \text{ g} \checkmark \\
 \text{Mass of solvent} &= 16 - 3.9 \\
 &= 12.1 \text{ g} \checkmark
 \end{aligned}$$

Solubility
 $= \frac{3.9}{12.1} \times 100 = 32.23 \text{ g/100g H}_2\text{O}$ (3)

26. The rate of a reaction depends on the concentration of reactants, temperature, and possibly a catalyst. A piece of magnesium ribbon was added to 100 cm³ of 1M HCl. The hydrogen evolved was collected and its volume was measured after every 30 seconds. Draw a set up to represent this information.

(3mks)

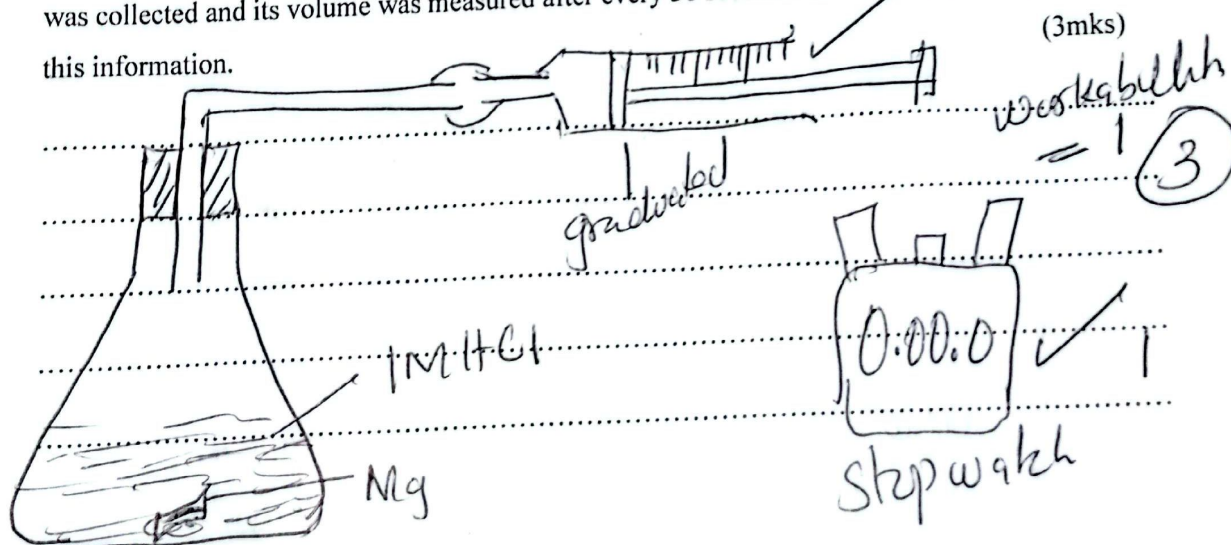

27. In an experiment, a student put equal volumes of mixtures of ethanoic acid in water and ethanoic acid in hexane in two test tubes as shown below. In each test tube, equal amounts of solid sodium hydrogen carbonate were added.

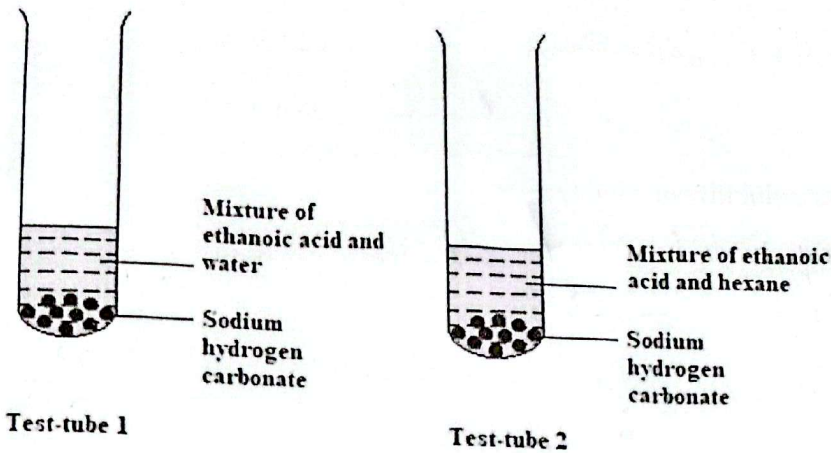

(a) State the observation which was made in each test-tube I

..... There was effervescence ✓ (1mk)

Test Tube II

..... No effervescence ✓ 1/2

(b) Explain the observations in (a) above

..... Ethanoic acid ionizes in water to ✓ (2mks)
 produce H^+ while in hexane
 it does not ionize but remain
 as molecules 2

THIS IS THE LAST PRINTED PAGE.